



US008754842B2

(12) **United States Patent**  
**Ludwig**

(10) **Patent No.:** **US 8,754,842 B2**  
(45) **Date of Patent:** **Jun. 17, 2014**

(54) **COMBINED DISPLAY AND IMAGE CAPTURE WITHOUT SIMPLE OR COMPOUND LENSES FOR VIDEO CONFERENCING EYE-CONTACT AND OTHER APPLICATIONS**

(75) Inventor: **Lester F. Ludwig**, Hillsborough, CA (US)

(73) Assignee: **Lester F. Ludwig**, San Antonio, TX (US)

(\* ) Notice: Subject to any disclaimer, the term of this patent is extended or adjusted under 35 U.S.C. 154(b) by 550 days.

(21) Appl. No.: **12/419,229**

(22) Filed: **Apr. 6, 2009**

(65) **Prior Publication Data**

US 2009/0231474 A1 Sep. 17, 2009

**Related U.S. Application Data**

(62) Division of application No. 09/601,384, filed as application No. PCT/US99/01789 on Jan. 27, 1999, now abandoned.

(60) Provisional application No. 60/072,762, filed on Jan. 27, 1998.

(51) **Int. Cl.**  
**G09G 3/36** (2006.01)

(52) **U.S. Cl.**  
USPC ..... **345/104**; 345/87; 348/252

(58) **Field of Classification Search**  
USPC ..... 345/104, 87; 348/252, 323  
See application file for complete search history.

(56) **References Cited**

U.S. PATENT DOCUMENTS

|           |     |         |                |            |
|-----------|-----|---------|----------------|------------|
| 4,935,812 | A * | 6/1990  | Bernard        | 375/240.25 |
| 4,991,020 | A * | 2/1991  | Zwirn          | 348/563    |
| 5,101,270 | A * | 3/1992  | Boone et al.   | 348/61     |
| 5,278,673 | A * | 1/1994  | Scapa et al.   | 358/473    |
| 5,835,627 | A * | 11/1998 | Higgins et al. | 382/167    |
| 5,920,401 | A * | 7/1999  | Street et al.  | 358/400    |

\* cited by examiner

*Primary Examiner* — William Boddie

*Assistant Examiner* — Saifeldin Elnafia

(74) *Attorney, Agent, or Firm* — Procopio, Cory, Hargreaves & Savitch LLP

(57) **ABSTRACT**

An integrated display and camera without simple or compound lenses comprising interleaved light-emitting and light-sensing/photosensor elements. Image formation without use of a simple or compound lens can be obtained via software algorithms operating on light-sensing measurements, for example implementing a two-dimensional deconvolution operation defined by the transfer function imposed by a microoptic array. For example, a microoptic aperture array can be configured to comprise localized optical overlaps which are readily deconvolved or otherwise solved for by an algorithm. Associated microoptic structures can be as simple as apertures or can be more complex, for example including microlenses. Display and photosensor elements can include color capabilities. Light-sensing elements can be similar, nearly, or essentially identical in structure and/or composition to the light-emitting element. Light-emitting elements can comprise an Organic Light Emitting Diode, and can be configured for light-detection modalities, for example emitting light and detecting light simultaneously. Applications include providing eye contact in video conferencing.

**21 Claims, 25 Drawing Sheets**

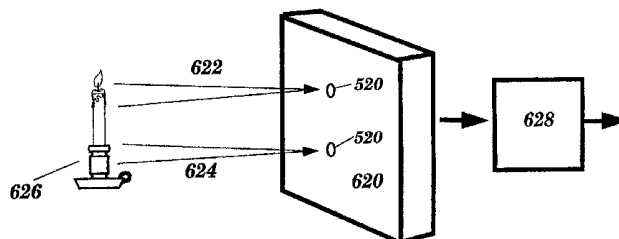
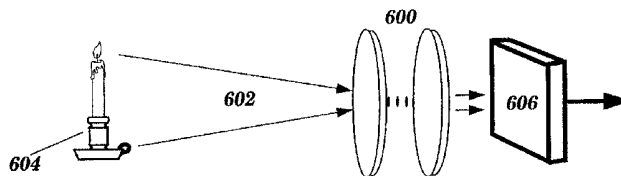
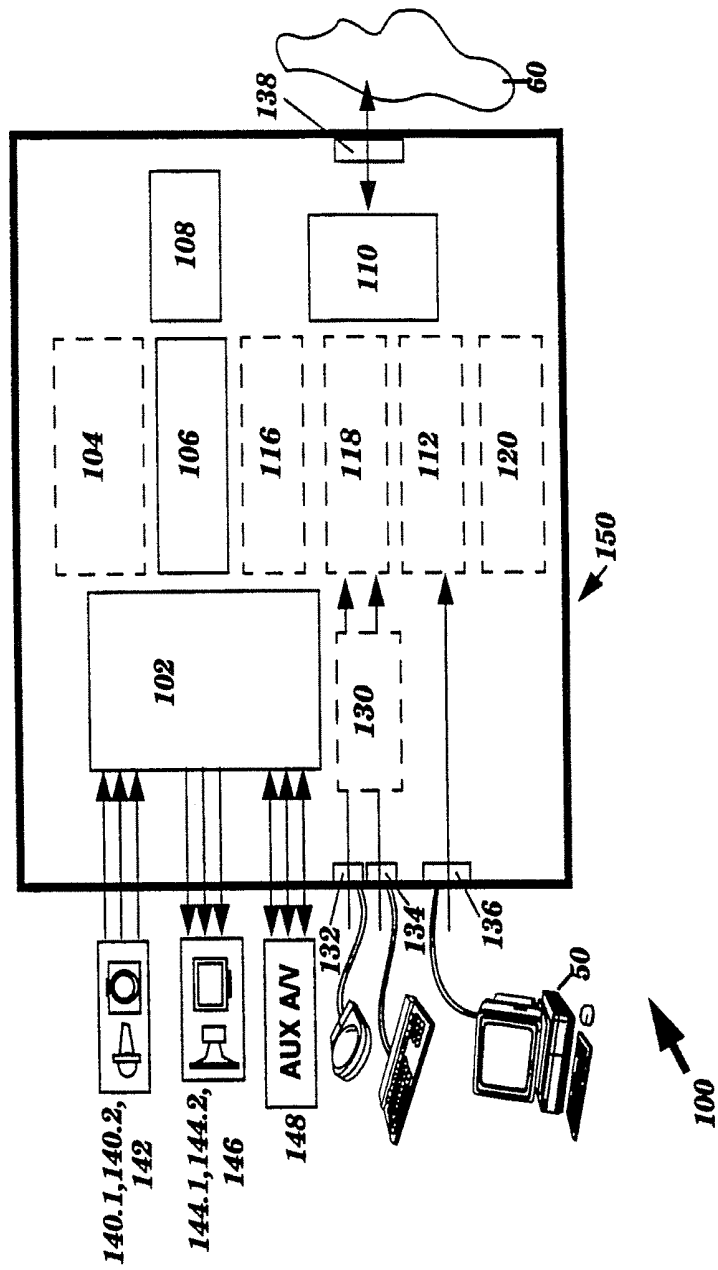

Figure 1



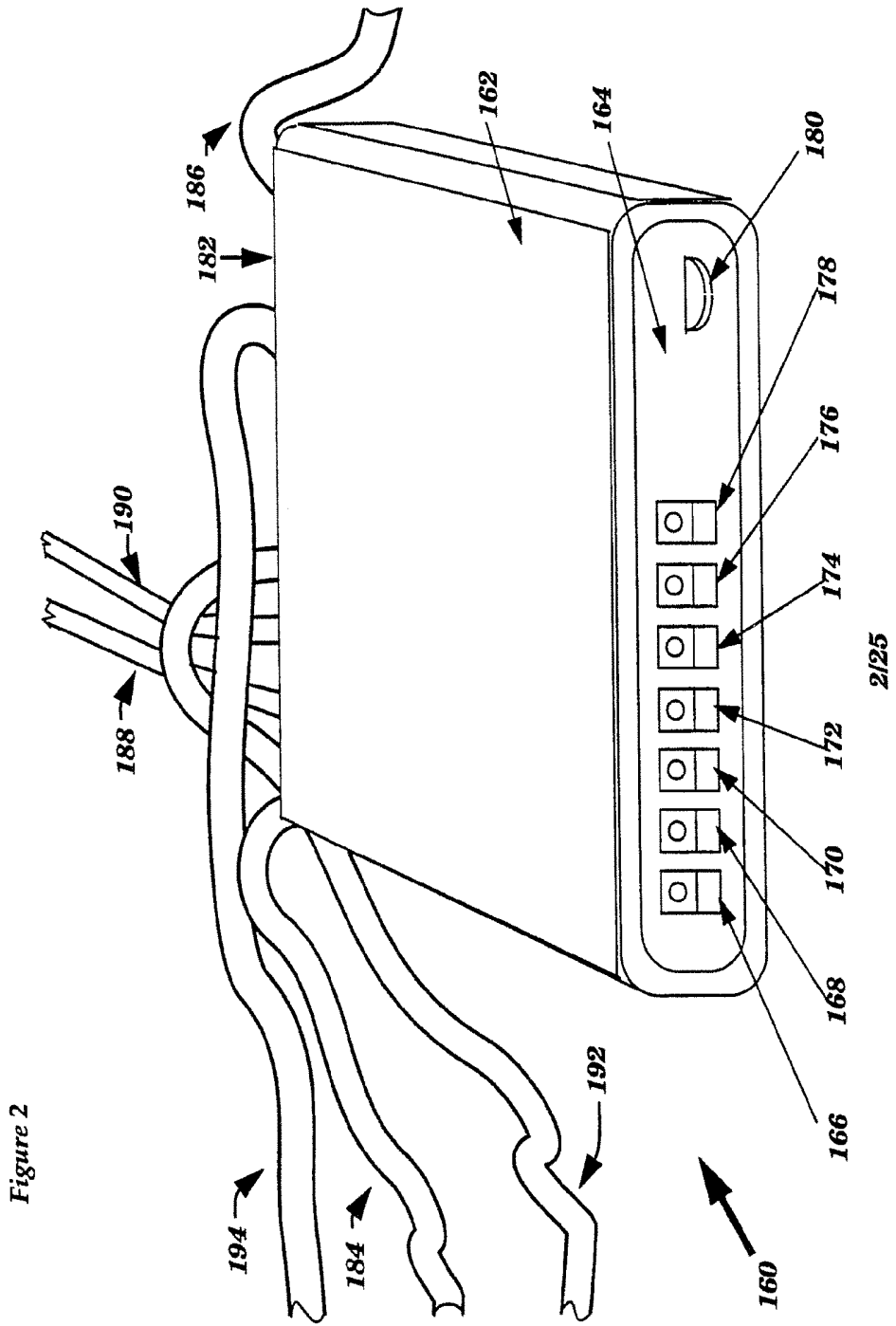

Figure 2

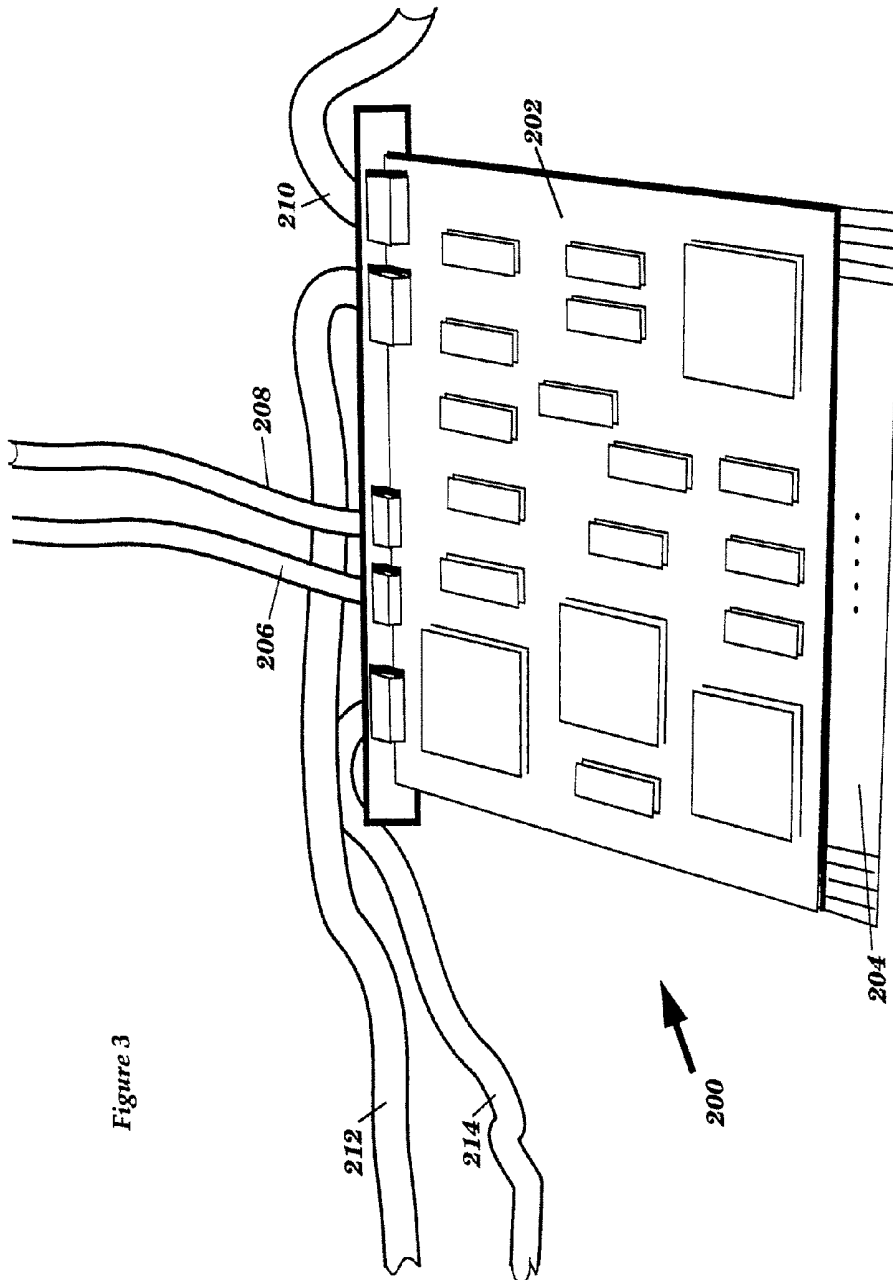

Figure 3

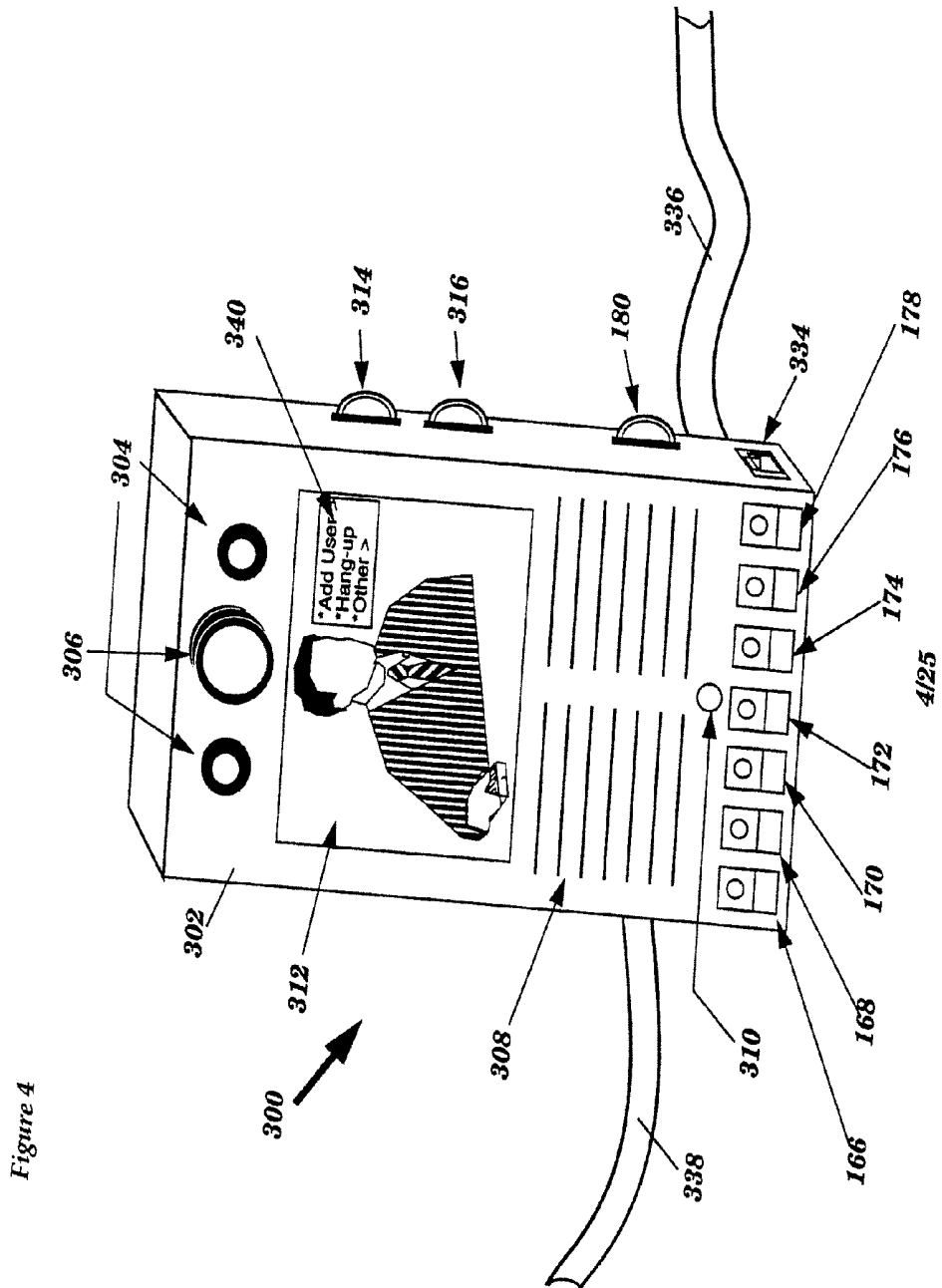

Figure 4

Figure 5

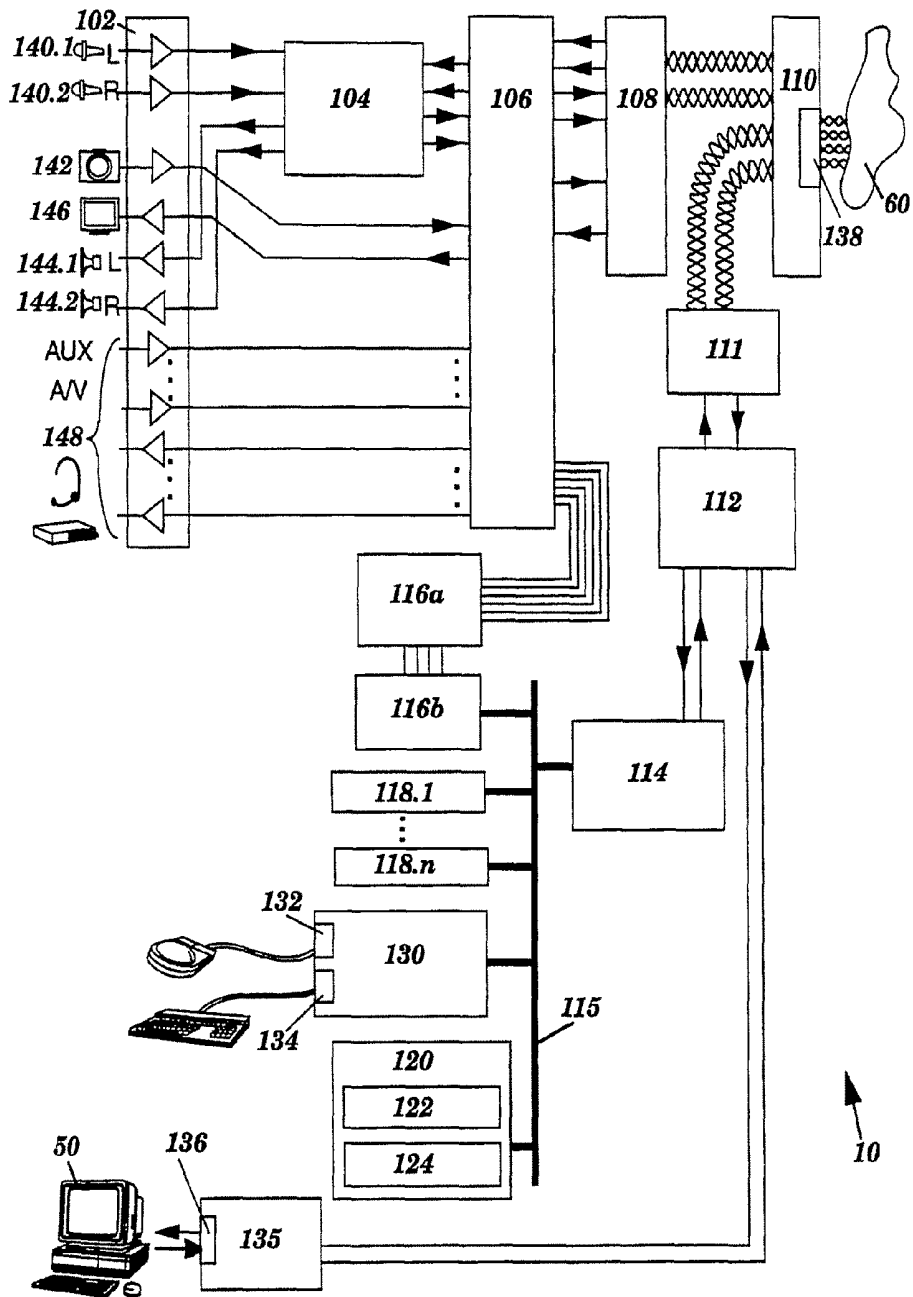

Figure 6

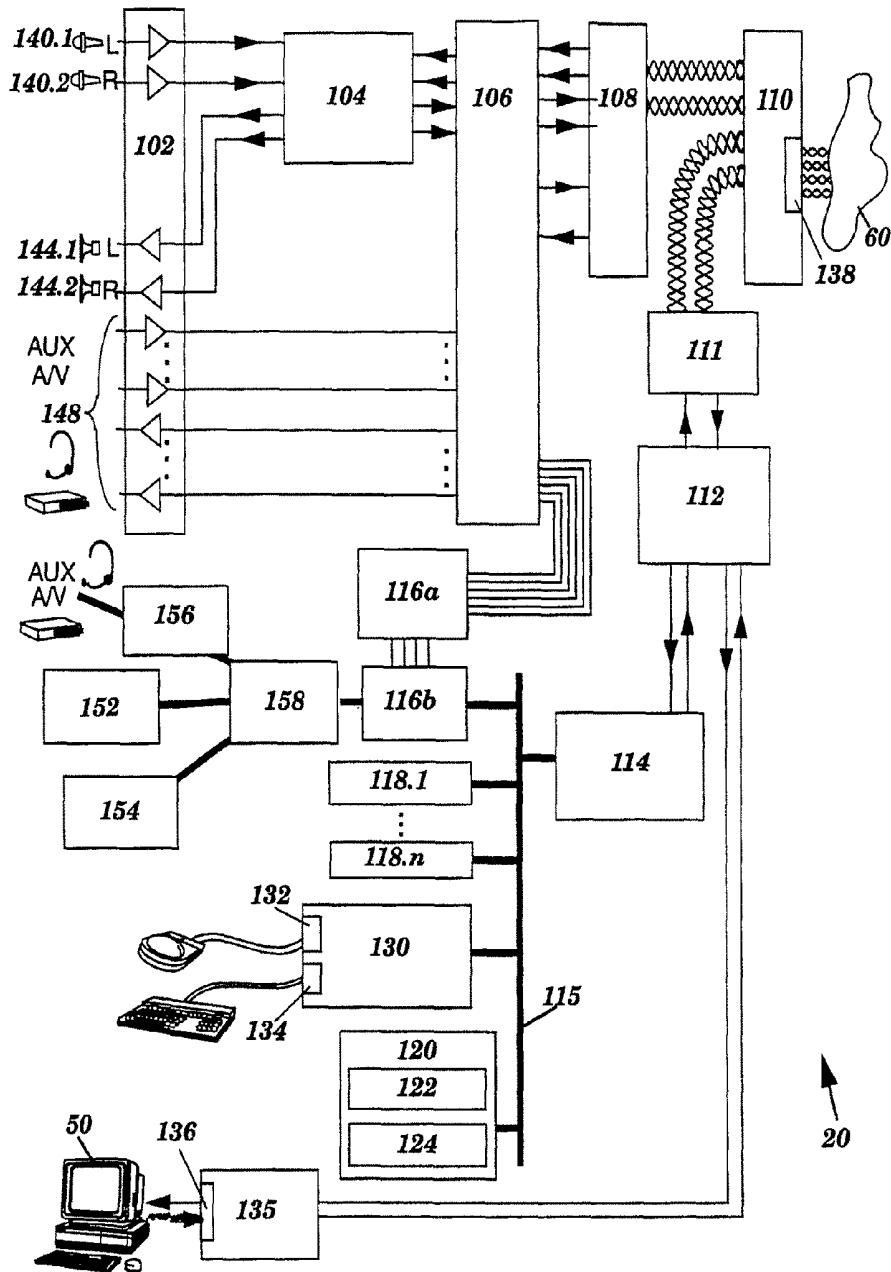
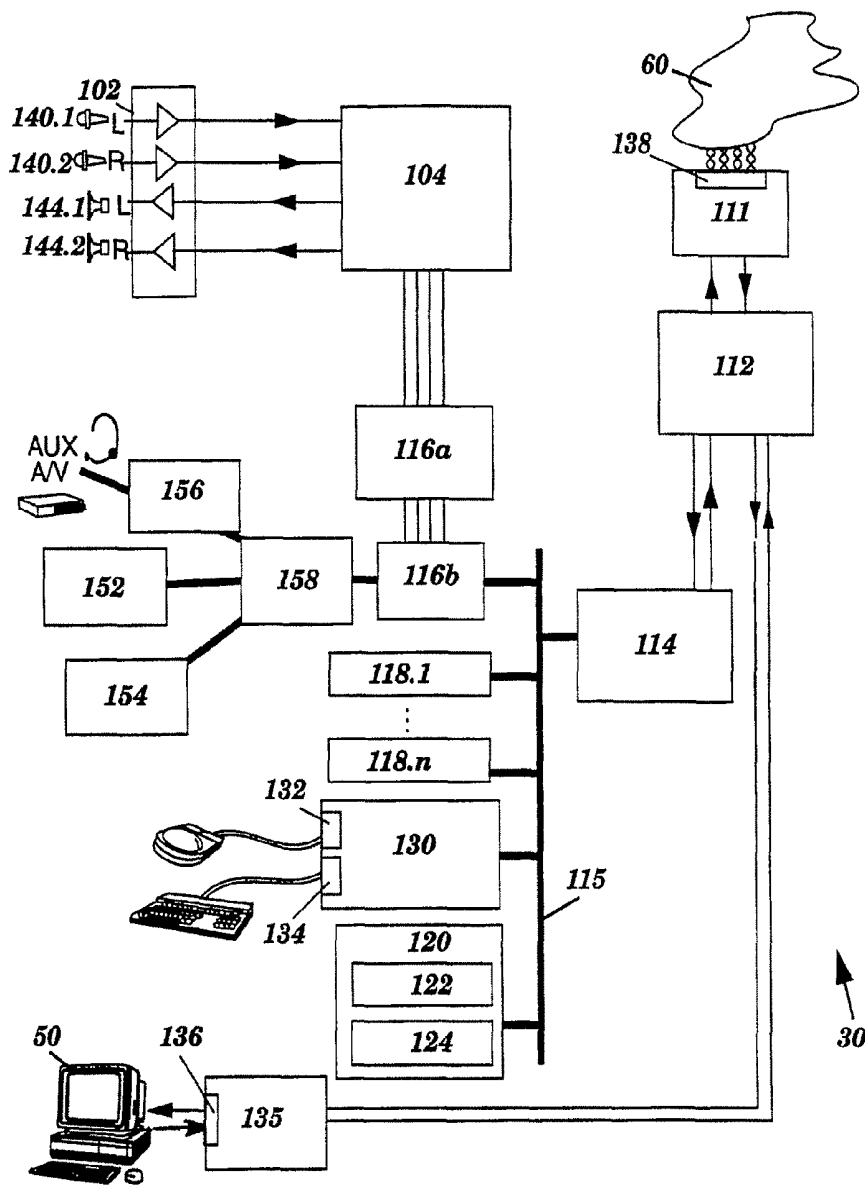

Figure 7



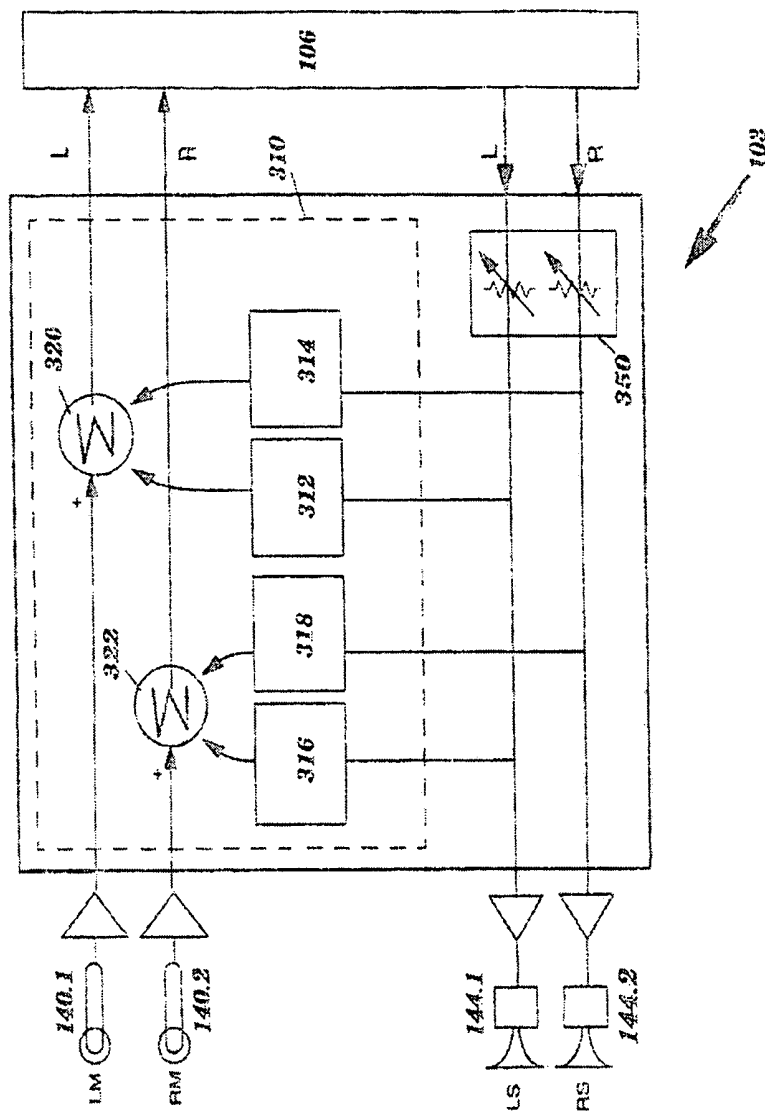

Figure 8

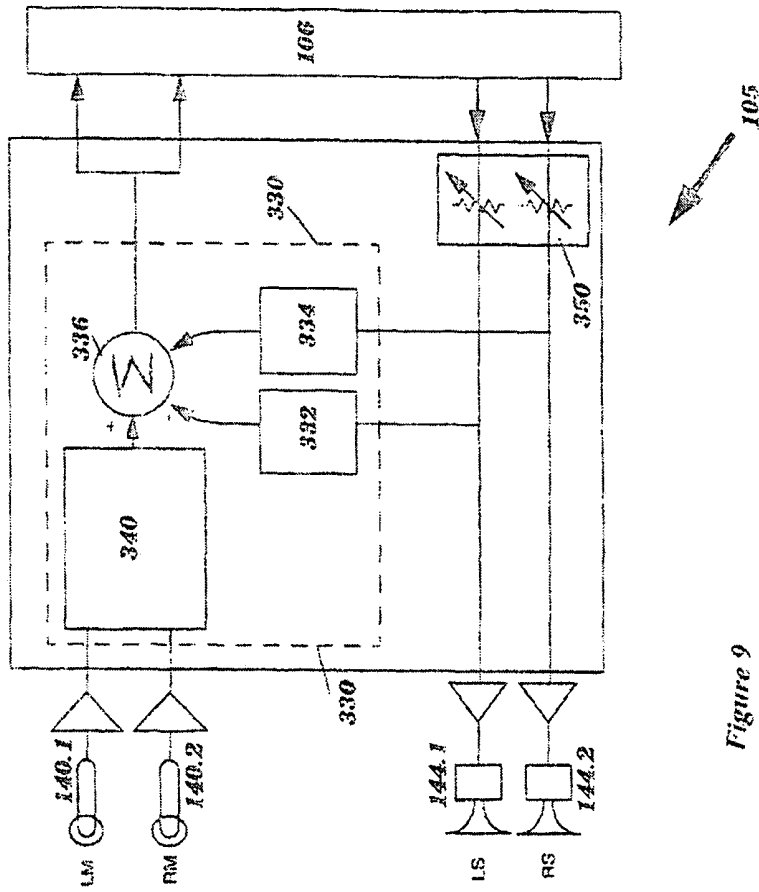

Figure 9

Figure 10

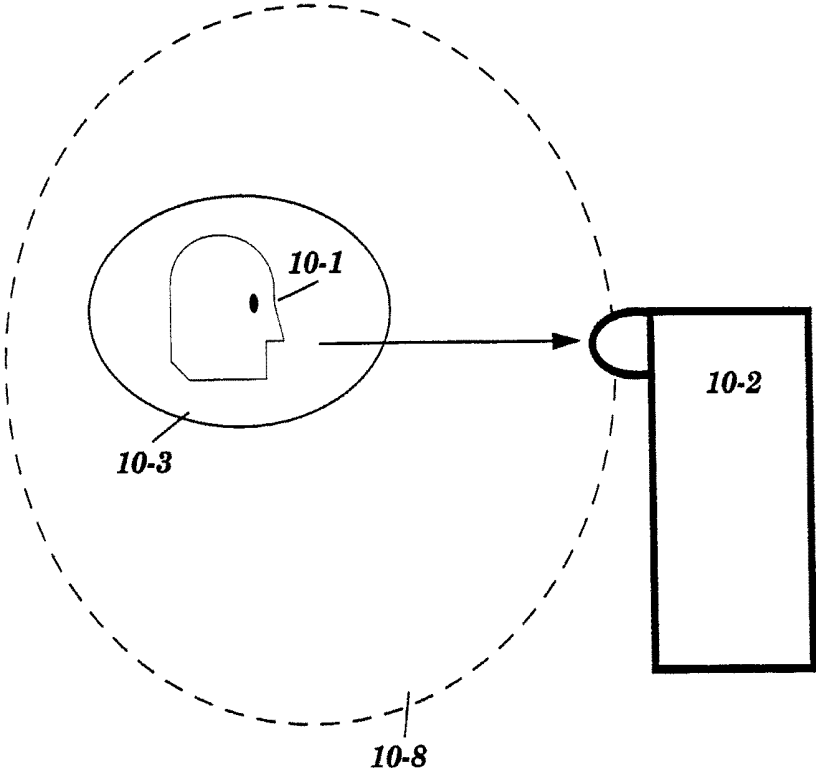

Figure 11

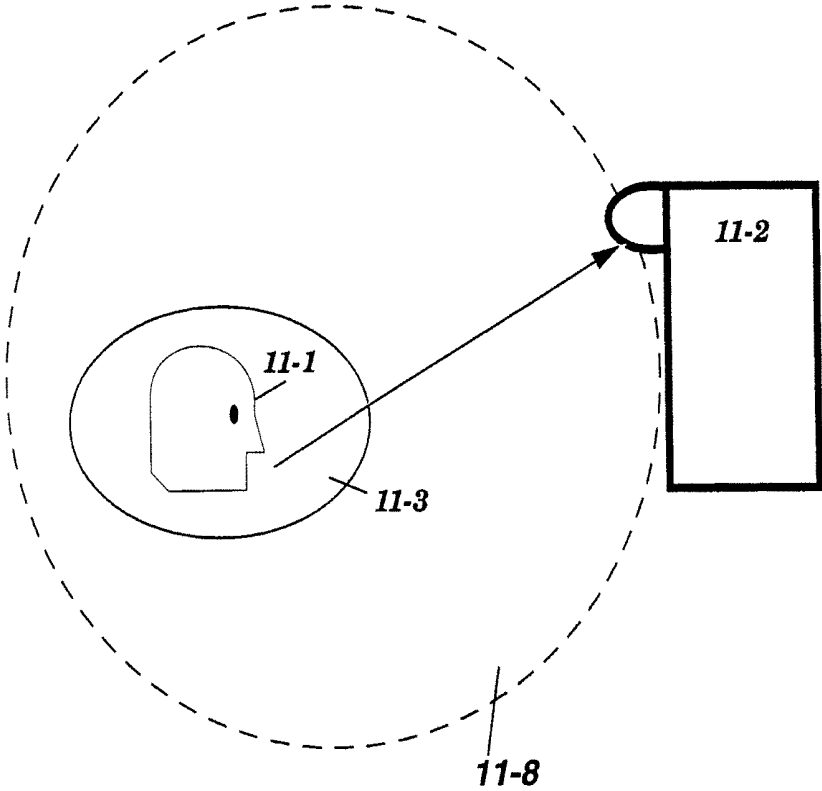

Figure 12

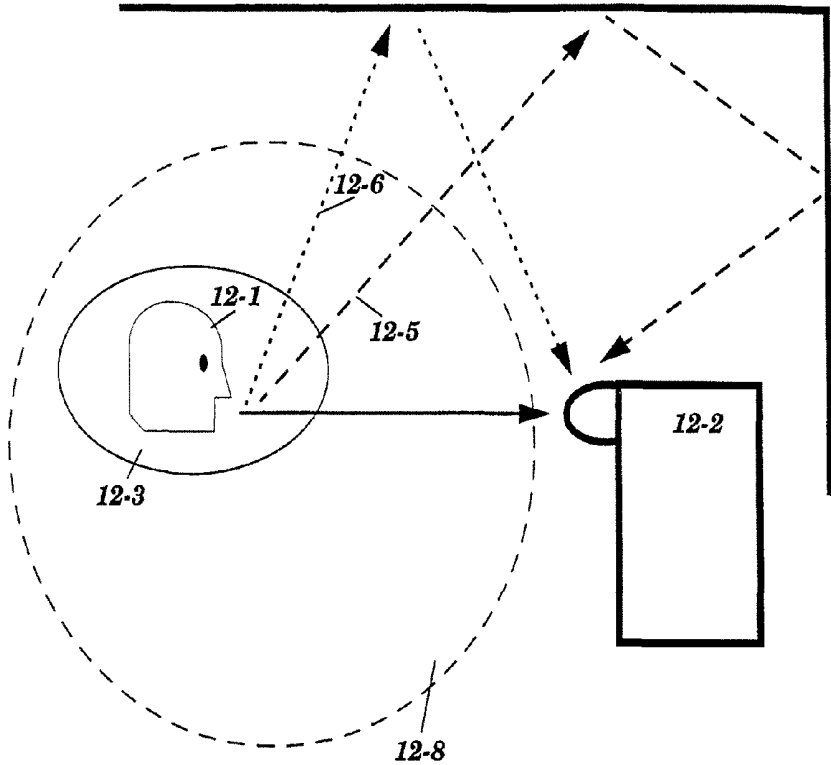
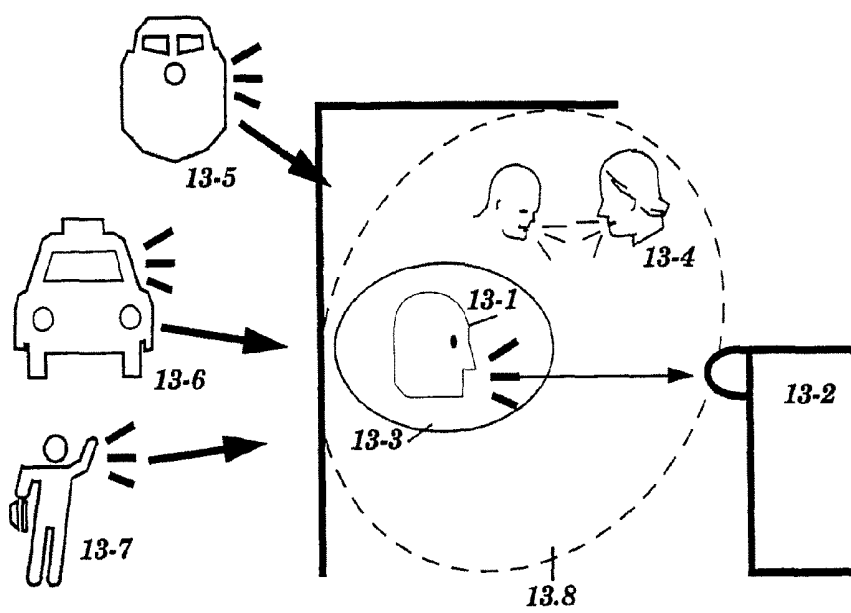

Figure 13



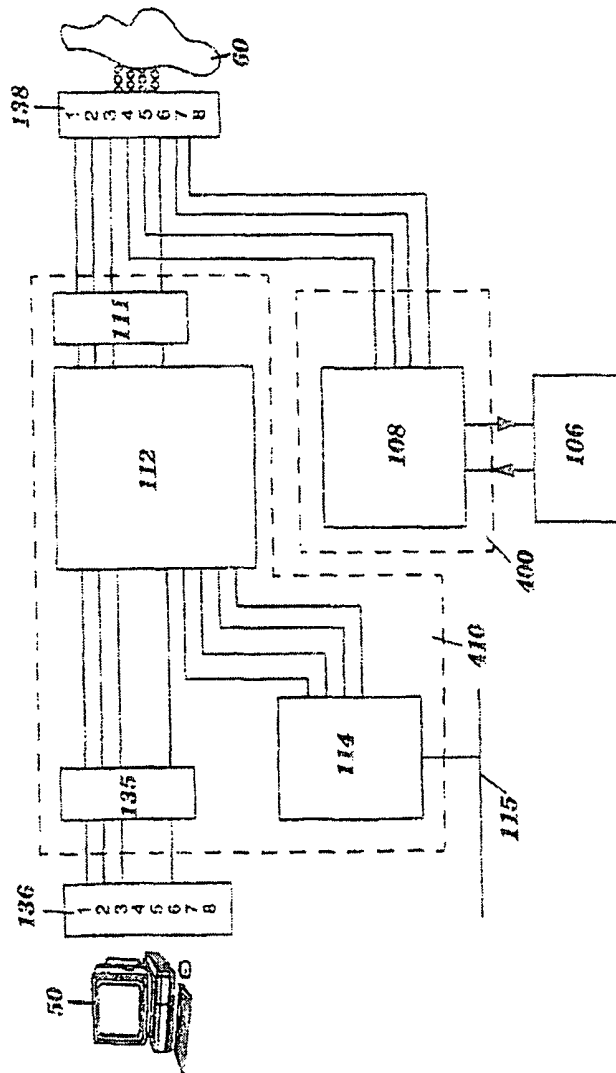

Figure 14

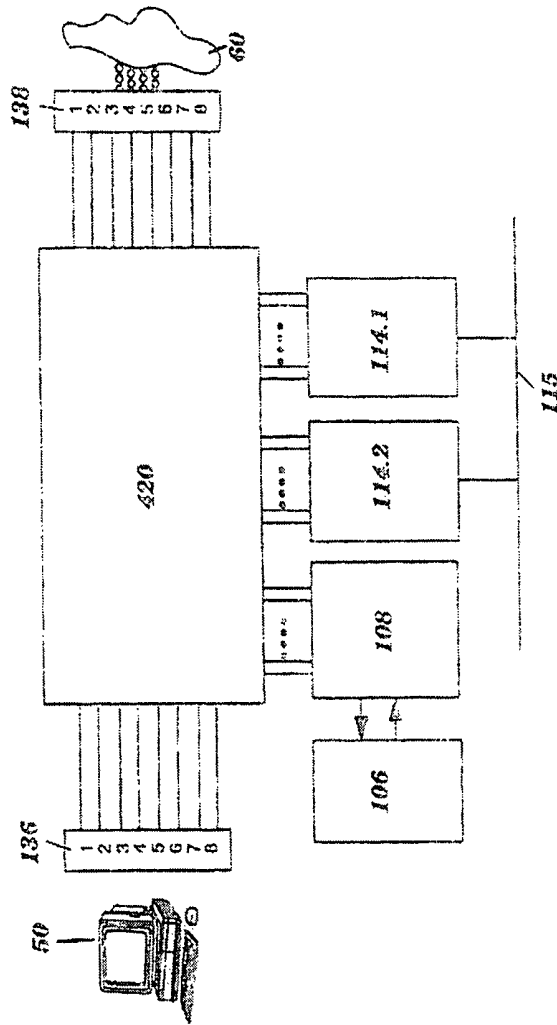

Figure 15

Figure 16

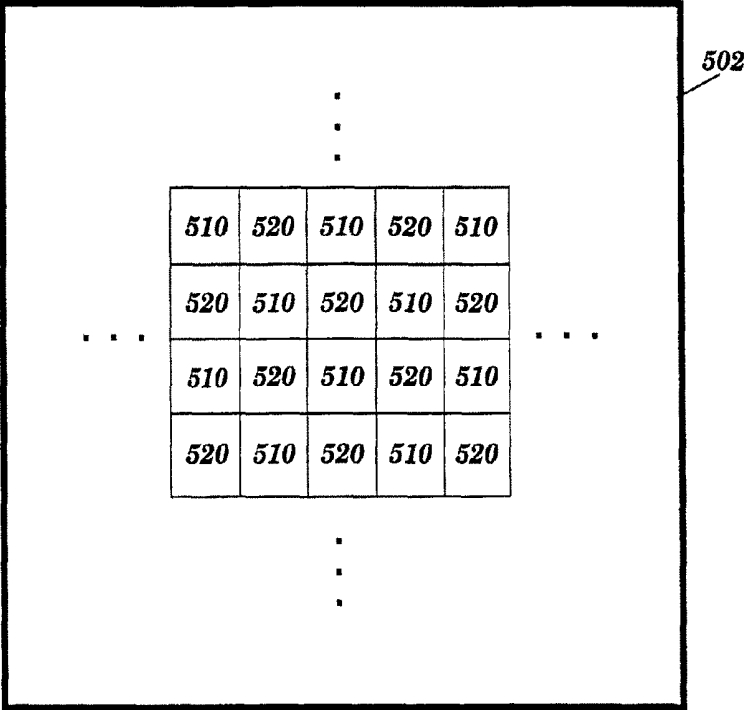
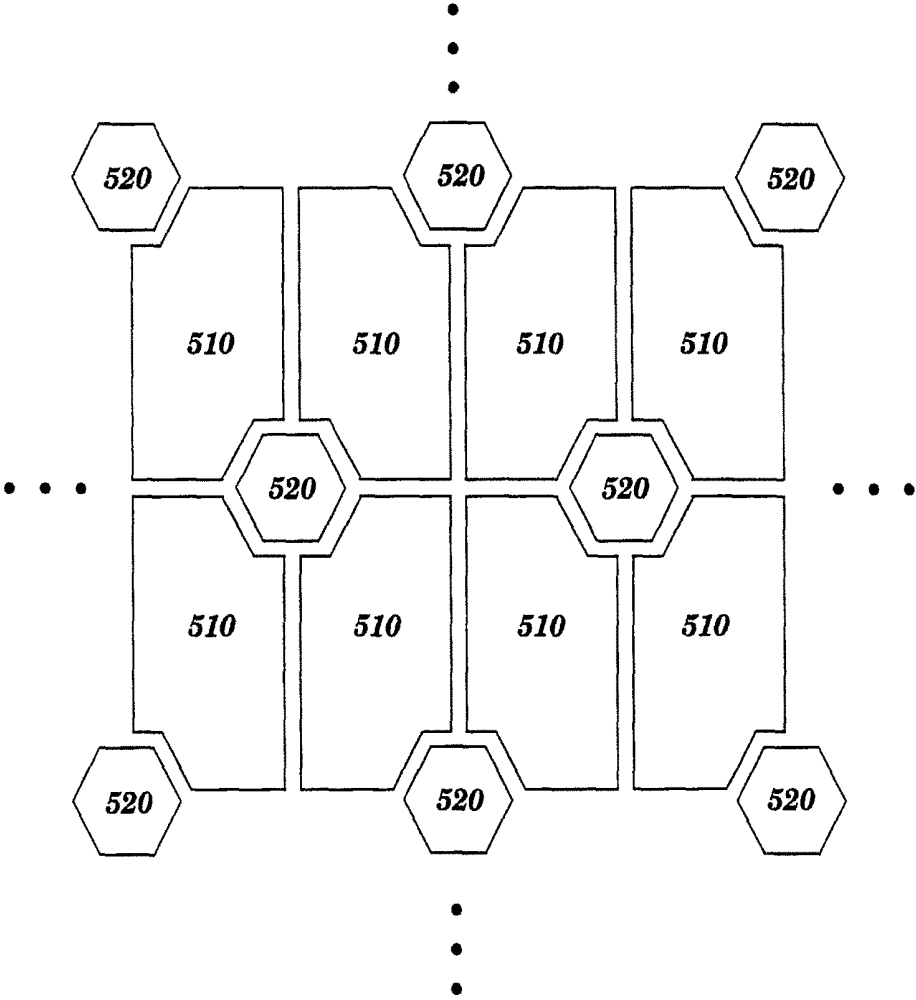

Figure 17

|   |   |   |   |   |   |   |
|---|---|---|---|---|---|---|
| R | b | G | r | B | g | R |
| g | R | b | G | r | B | g |
| B | g | R | b | G | r | B |
| r | B | g | R | b | G | r |
| G | r | B | g | R | b | g |
| b | G | r | B | g | R | b |
| B | b | G | r | B | g | R |

Figure 18



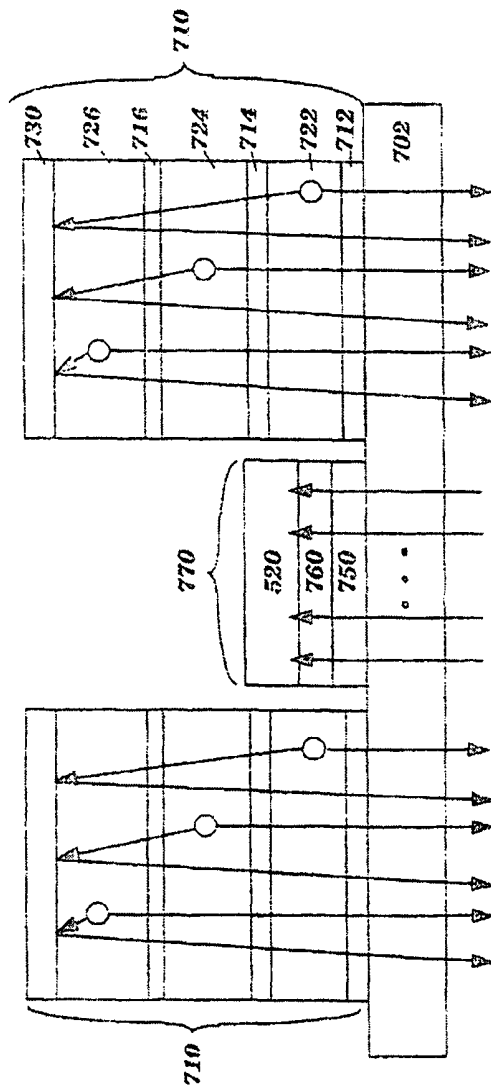

Figure 19

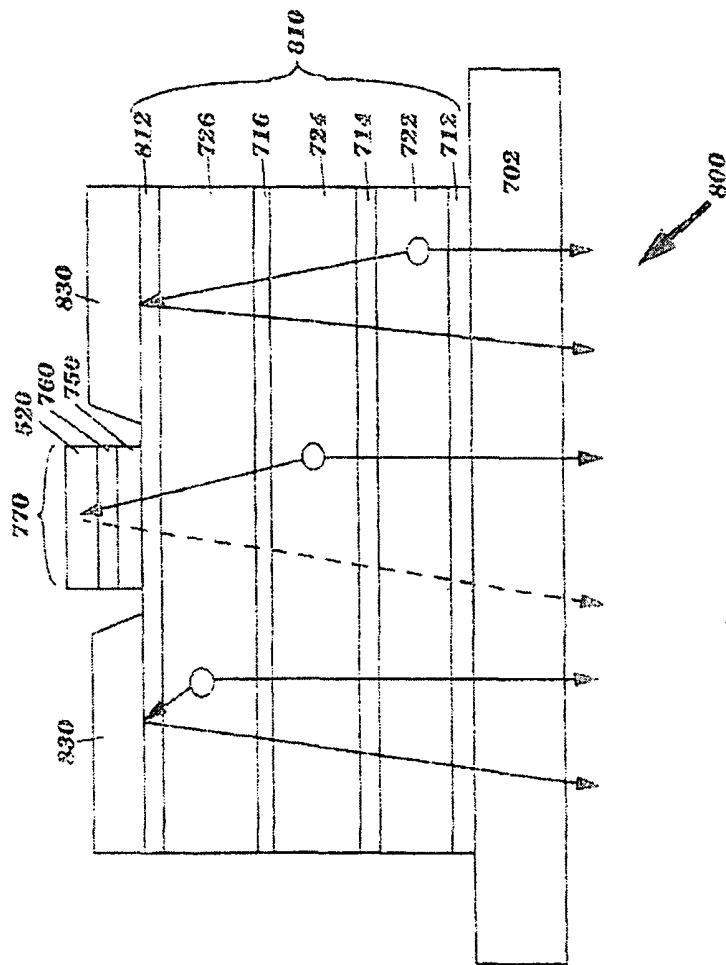

Figure 20

Figure 21

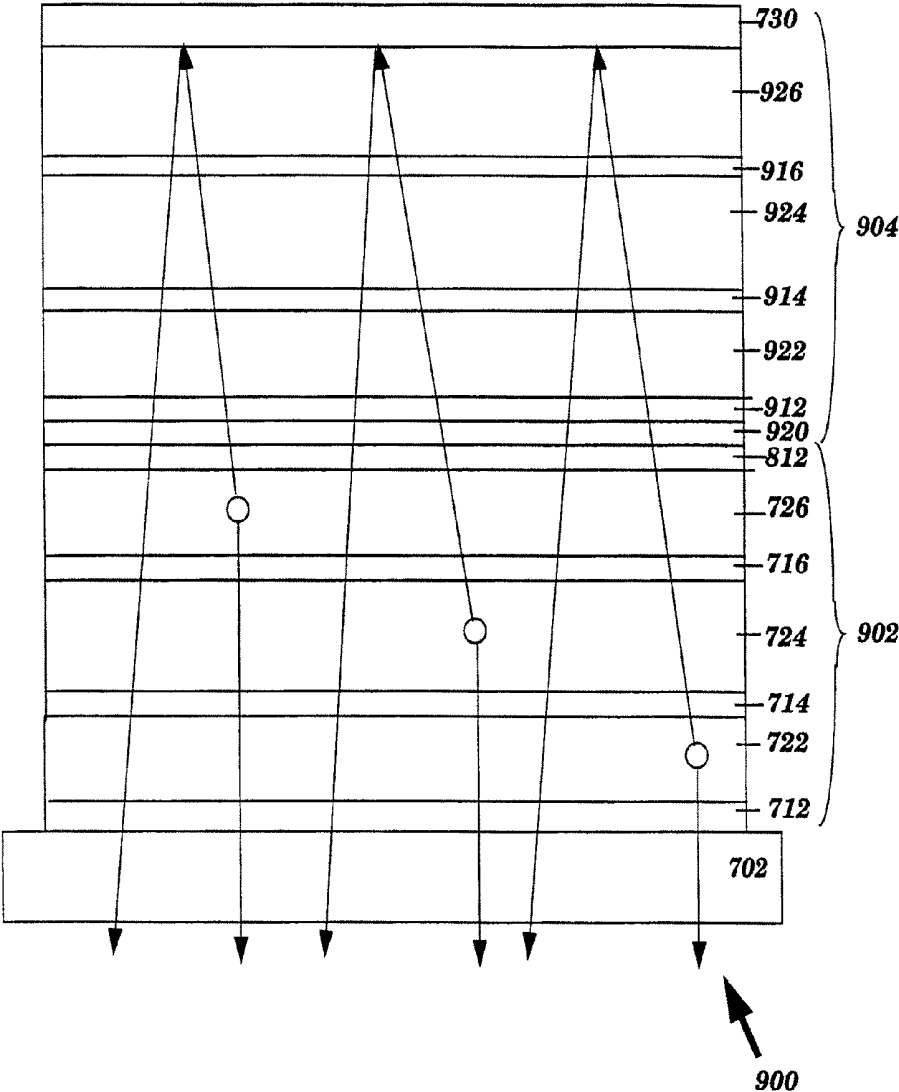
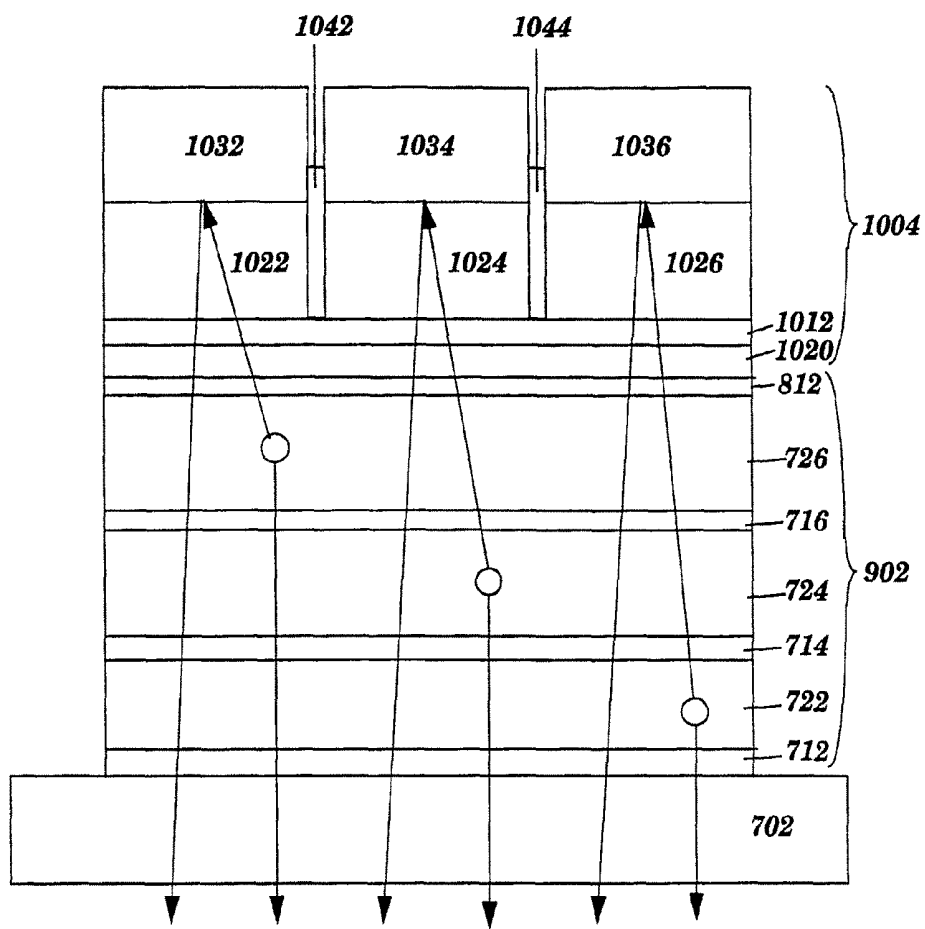

Figure 22



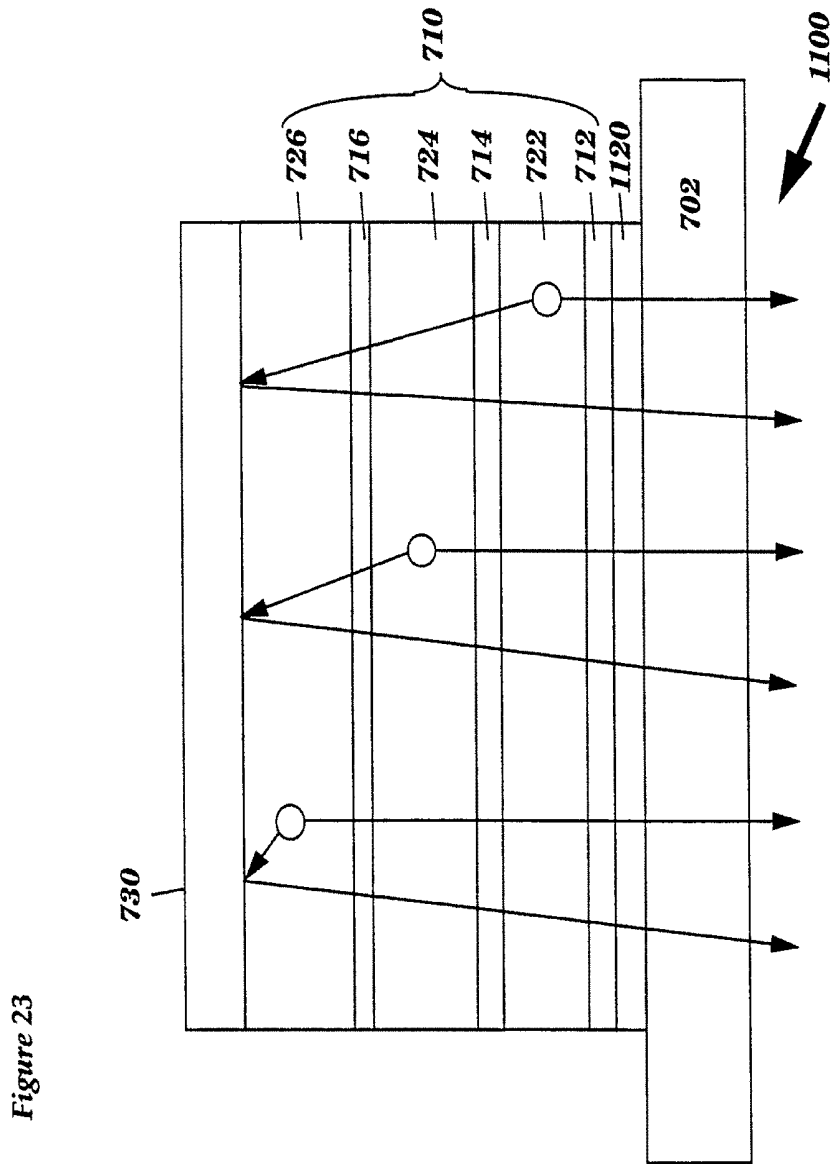

Figure 24

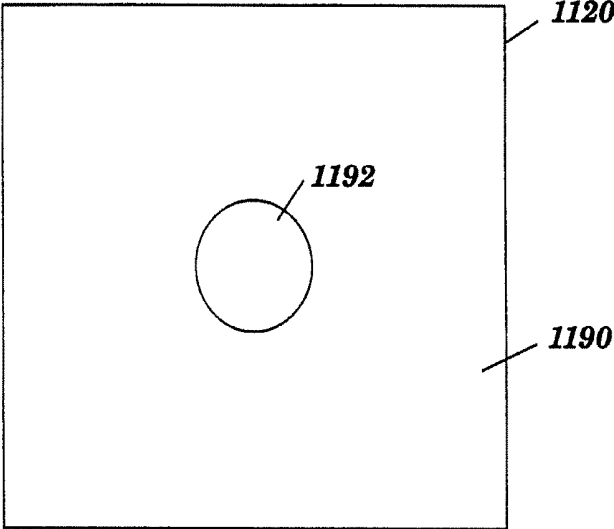
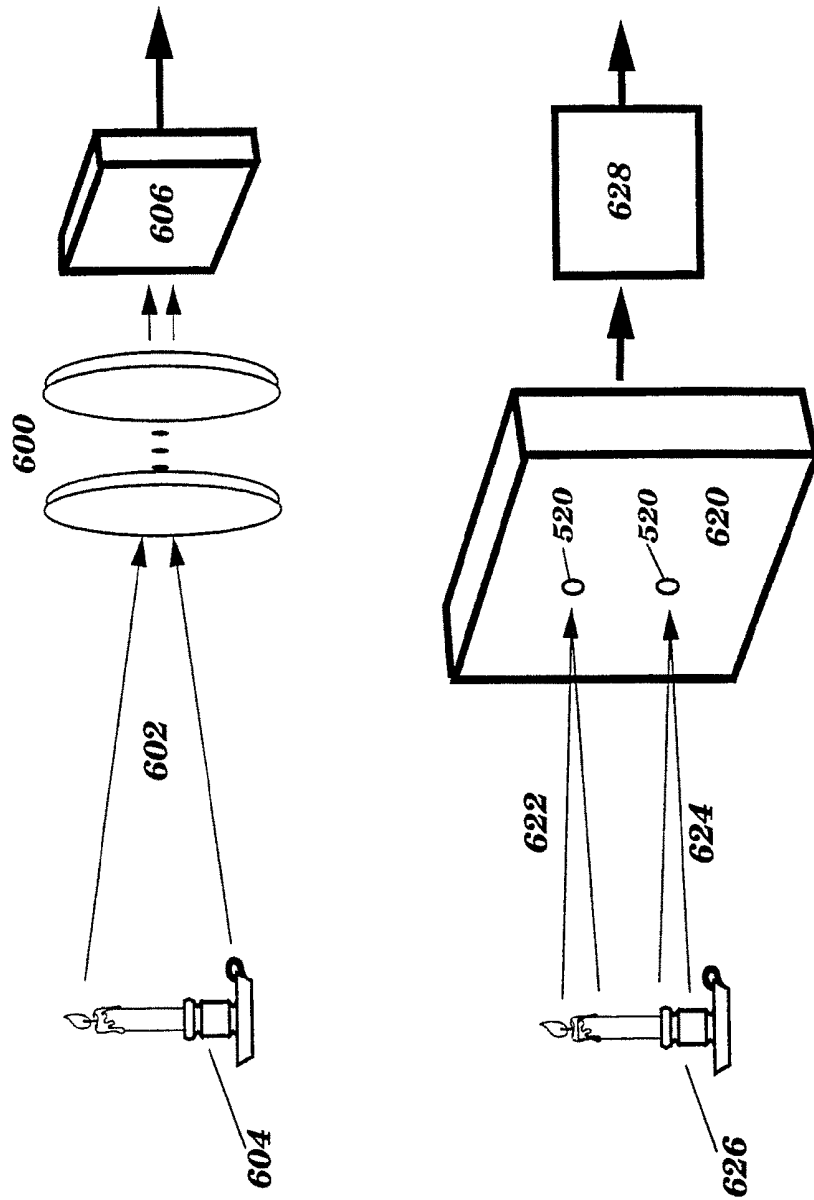

Figure 25



**COMBINED DISPLAY AND IMAGE CAPTURE  
WITHOUT SIMPLE OR COMPOUND LENSES  
FOR VIDEO CONFERENCING  
EYE-CONTACT AND OTHER APPLICATIONS**

CROSS-REFERENCE TO RELATED  
APPLICATIONS

This is a Divisional of U.S. patent application Ser. No. 09/601,384 filed Jul. 27, 2000, now abandoned which was an application filed under 35 U.S.C. §371 of International Patent Application Ser. No. PCT/US1999/001789, filed Jan. 27, 1999, which claims the benefit of U.S. Provisional Application Ser. No. 60/072,762, filed Jan. 27, 1998, the disclosures of all of which are incorporated herein by reference.

## 1. BACKGROUND OF THE INVENTION

### 1.1 Field of the Invention

The present invention relates generally to multimedia conferencing systems, and more particularly to multimedia-enabled communication and computing devices. Still more particularly, the present invention is a device for providing real-time multimedia conferencing capabilities to one or more companion computers or on a stand-alone basis.

### 1.2 Background

Early computers were large, clumsy, difficult-to-operate and unreliable room-sized systems shared within a single location. Similarly, early video and graphics teleconferencing systems suffered from the same drawbacks, and were also shared within a single location. With regard to computers, technological innovations enabled the advent of desktop "personal computers." Relative to teleconferencing systems, new technologies were also introduced, such as those described in U.S. Pat. No. 5,617,539, entitled "Multimedia Collaboration System with Separate Data Network and A/V Network Controlled by Information Transmitting on the Data Network," that brought high-quality, reliable video and graphics teleconferencing capabilities to a user's desktop. In both early desktop personal computers and conferencing systems, there were and remain many incompatible implementations.

Digital technology innovations targeted at working in conjunction with market forces gave rise to standardized desktop computer platforms, such as Microsoft/Intel machines and Apple machines, which have existing and strengthening unifying ties between them. The standardization of converging platforms unified fragmentations that existed within the computer hardware and software industries, such that immense economies of scale lowered the per-desktop development and manufacturing costs. This in turn greatly accelerated desktop computer usage and promoted the interworking between applications such as work processing, spreadsheet, and presentation tool applications that freely exchange data today. As a result, businesses employing such interworking applications became more efficient and productive. The push for greater efficiency has fueled the development of additional innovations, which further led to developments such as the explosion in electronic commerce as facilitated by the world-wide Internet.

Relative to present-day desktop conferencing, there are many networking approaches characterized by varying audio/video (A/V) quality and scalability. In recent years, customers have assumed a wide range of positions in their investments in such technologies. At one end of this range, various types of dedicated analog A/V overlay networks exist that deliver high-quality A/V signals at a low cost. At another

end of this range are local area data network technologies such as switched Ethernet and ATM data hubs that function with high-performance desktop computers. These desktop computers and data networking technologies currently support only lower-quality A/V capabilities at a relatively high cost. Despite this drawback, these desktop computers and data networking technologies are believed to be the preferred path for eventually providing high-quality A/V capabilities at a low cost. Other A/V networking solutions, such as ISDN to the desktop, also lie in this range.

Within each of many separate networked A/V technology "islands," various approaches toward providing multimedia applications such as teleconferencing, video mail, video broadcast, video conference recording, video-on-demand, video attachments to documents and/or web pages, and other applications can be performed only in fragmented ways with limited interworking capability. For many years, it has been projected that the desktop computer industry and the data networking industry will solve such fragmentation and interworking problems, and eventually create a unified, low-cost solution. Several generations of these technologies and products have consistently fallen short of satisfying this long-felt need. Furthermore, it is likely to be disadvantageous to continue to rely upon the aforementioned industries to satisfy such needs. For example, if the introduction of today's standardized multi-method fax technology had been held back by those who maintain that the idea that all electronic text should only be computer ASCII (as advocated, for example, by M.I.T. Media Lab Director Negroponte), a great amount of the fax-leveraged domestic and international commerce that has occurred since the early 1980's may not have occurred. Desktop multimedia technologies and products are currently in an analogous position, as it is commonly accepted that it will be only the desktop computer and data networking industries that at some point in the future will make high-quality networked A/V widely and uniformly available, and at the same time it is doubtful that this will occur any time soon.

What is sorely needed, given the pace and market strategies of the desktop computer and data networking industries, is an integration of separate technology and application islands into a single low-cost, manufacturable, reliable real-time multimedia collaboration apparatus capable of supporting a wide range of A/V networking technologies; A/V applications; and A/V and data networking configurations in a wide variety of practical environments. A need also exists for a design or architecture that makes such an apparatus readily adaptable to future technological evolution, such that the apparatus may accommodate evolving or new families of interrelated standards.

## 2. SUMMARY OF THE INVENTION

This invention relates to a multimedia device for use in multimedia collaboration apparatus and systems. Such apparatus and systems also typically contain processing units, audio reception and transmission capabilities, as well as video reception and transmission capabilities. The reception and transmission capabilities allow analog audio/video signal transfer over UTP wires for audio transmit/receive. Further included in these capabilities is audio/video signal transfer via encoding both audio and video signals on a single set of UTP wires, for example, through frequency modulation (FM). The video reception capabilities may include support for a primary digital video stream and an auxiliary digital video stream. The reception, transmission, encoding, and decoding capabilities could exist in a single packaging. This or another single packaging can support a plurality of multi-

media network signal formats, including analog plus digital or all digital. Different wire pair combinations could also be supported, such as 10 and 100 Megabit-per-second (MBPS) Ethernet, as well as Gigabit Ethernet, via Unshielded Twisted Pair (UTP) wiring. Other embodiments could include support for other or additional networking protocols, such as Asynchronous Transfer Mode (ATM) networking. AV reception capabilities include adaptive stereo echo-canceling capabilities and synthetic aperture microphone capabilities.

In addition, this invention may include a single packaging allowing for stereo echo-canceling capabilities. The invention also includes synthetic aperture microphone capabilities, such as capabilities for programmably adjusting a position of a spatial region corresponding to maximum microphone audio sensitivity. The synthetic aperture microphone capabilities typically are implemented through an audio signal processing unit and a plurality of microphones.

This system further embodies multiport networking capabilities in which a first port couples to a multimedia network which can carry multimedia signals in multiple format, and a second port couples to a set of computers. These multiport networking capabilities also include data packet destination routing.

Moreover, the invention includes a memory in which an operating system and application software having internet browsing capabilities resides. A graphical user interface is included in the invention with I/O capabilities that support graphical manipulation of a cursor and pointing icon.

The multimedia apparatus also includes a display device having integrated image capture capabilities. Typically, the display device is a single substrate upon which display elements and photosensor elements reside. The display device has display elements interleaved with a plurality of photosensor elements in a planar arrangement. Further, the display elements may be integrated with the photosensor elements. The display elements are typically optically semitransparent.

Photosensor elements typically occupy a smaller area than the display elements and are fabricated with different geometries such that the nonluminescent spacing between display elements is reduced. Also, the photosensor elements and sets of display elements are fabricated with optical structures to minimize perceived areas of nonluminescence between a set of displayed pixels.

Among other characteristics of the photosensor elements are: (1) a plurality of photosensor elements in the display device are individually-apertured, and (2) a set of photosensor elements in the display device includes dedicated microoptic structures. Also, image processing capabilities are coupled to the photosensor elements in the display device.

The display device can operate to display an image on a screen while capturing external image signals. This is done by outputting display signals to a set of display elements while capturing external image signals using a set of photosensor elements. These sets of display and photosensor elements occupy different lateral regions across the plane of the display device. The first set of display elements comprises at least one display line across the screen, and the first set of photosensor elements comprises a photosensor line across the screen. Display lines and photosensor lines may be scanned in a temporally or spatially separate manner.

The device performs a set of optical image processing operations by receiving external image signals through a set of apertures or a set of microoptic elements. The device then outputs an electrical signal at each photosensor element within a set of photosensor elements corresponding to the set

of apertures. These electrical signals have magnitudes dependent upon the light intensity detected by the photosensor elements.

### 3. BRIEF DESCRIPTION OF THE DRAWINGS

FIG. 1 is a high-level block diagram of a multimedia collaboration device constructed in accordance with the present invention.

FIG. 2 is a high-level perspective view illustrating a box package for the multimedia collaboration device.

FIG. 3 is a high-level drawing of a plug-in card package for the multimedia collaboration device, which also includes a bus interface.

FIG. 4 is a perspective view of a stand-alone package for the multimedia collaboration device, which includes a camera, a display, a microphone array, and speakers.

FIG. 5 is a block diagram of a first embodiment of a multimedia collaboration device constructed in accordance with the present invention, and which provides primary and auxiliary (AUX) support for analog audio/video (A/V) input/output (I/O), and further provides support for networked digital streaming.

FIG. 6 is a block diagram of a second embodiment of a multimedia collaboration device, which provides primary support for analog audio I/O and digital visual I/O, and further supports analog and digital auxiliary A/V I/O, plus networked digital streaming.

FIG. 7 is a block diagram of a third embodiment of a multimedia collaboration device, which provides primary support for analog audio I/O and digital visual I/O, support for digital auxiliary A/V I/O, and support for networked digital streaming.

FIG. 8 is a block diagram of an adaptive echo-canceled stereo microphone and stereo speaker arrangement within an audio signal conditioning unit of the present invention.

FIG. 9 is a block diagram of an adaptive echo-canceled mono-output synthetic aperture microphone arrangement, assuming stereo speakers, within the audio signal conditioning unit, which is of particular value in noisy environments such as office cubicles or service depot areas.

FIG. 10 is an illustration showing an exemplary localized primary hot-spot, within which the synthetic aperture microphone has enhanced sensitivity to sound waves produced by a user.

FIG. 11 is an illustration showing exemplary primary hot-spot directivity, where the synthetic aperture microphone captures or rejects directionally-specific sound energy from a user within a primary hot-spot that is offset relative to that shown in FIG. 10.

FIG. 12 is an illustration showing exemplary reflected speech energy rejection by the synthetic aperture microphone.

FIG. 13 is an illustration showing exemplary ambient audio noise rejection by the synthetic aperture microphone.

FIG. 14 is a block diagram of a first embodiment of a first and a second multimedia network interface provided by the present invention.

FIG. 15 is a block diagram of a second embodiment of a first and a second multimedia network interface provided by the present invention.

FIG. 16 is an illustration of a first photosensor and display element planar interleaving technique.

FIG. 17 is an illustration of an exemplary photosensor element color and display element color distribution scheme.

FIG. 18 is an illustration of a second alternating photosensor and display element interleaving technique, in which pho-

tosensor and display element geometries and size differentials aid in minimizing pixel pitch and maximizing displayed image resolution.

FIG. 19 is a cross-sectional view showing a full-color pixel array integrated with a photosensor element array upon a common substrate.

FIG. 20 is a cross-sectional view showing an integrated full-color pixel/photosensor element, which may form the basis of an integrated display element/photosensor element array.

FIG. 21 is a cross-sectional view of a first full-color emitter/detector.

FIG. 22 is a cross-sectional view of a second full-color emitter/detector.

FIG. 23 is a cross-sectional view of a third full-color emitter/detector.

FIG. 24 is a top-view of an exemplary microoptic layer having different optical regions defined therein.

FIG. 25 is an illustration showing individually-apertured photosensor elements capturing light from portions of an object and outputting signals to an imaging unit.

#### 4. DETAILED DESCRIPTION

##### 4.1 General Provisions

The present invention comprises a device that provides analog audio/video and/or digital audio/visual (both referred to herein as A/V) multimedia collaboration capabilities to a user coupled to a multimedia network, such as a Multimedia Local Area Network (MLA/V) as described in U.S. Pat. No. 5,617,539 the disclosure of which is incorporated herein by reference.

The present invention may operate either in conjunction with one or more user's computers or in a stand-alone manner, and may support two-way videoconferencing, two-way message publishing, one-way broadcast transmission or reception, one-way media-on-demand applications, as well as other audio, video, and/or multimedia functionality or operations. The present invention may support such multimedia functionality across a wide range of multimedia network implementations, including mixed analog and digital and/or all-digital multimedia networks. When used in conjunction with a companion computer (i.e., desktop, laptop, special-purpose workstation or other type of computer), the present invention may operate as a high-performance multimedia processing device that offloads potentially computation-intensive multimedia processing tasks from the companion computer.

The present invention unifies several previously segregated or disparate audio-, video-, and/or multimedia-related technologies in a single physical device that supports multiple multimedia applications and multiple network signal formats and standards. Such technologies may include hardware and/or software that provide audio signal processing, analog-to-digital (A-D) and digital-to-analog (D-A) conversion, compression and decompression, signal routing, signal level control, video conferencing, stored video-on-demand, internet browsing, message publishing, and data networking capabilities. Heretofore, these technologies were typically implemented via separate devices and/or systems that may have operated in accordance with different data or signal formats and/or standards, and that offered limited ability (if any) to interface or operate together.

In particular, the multimedia collaboration device described herein supports functionality that may include the following:

1. Audio signal handling:
  - a) stereo speakers—to provide realistic audio reproduction capabilities needed for multimedia presentations, music, and multiport teleconferencing, including support for three-dimensional sound and audio positioning metaphors;
  - b) adaptive echo-canceled stereo speakers for the environment and mono or stereo microphone—to provide high-quality, realistic audio interactions and eliminate echo and/or feedback in conferencing situations; and
  - c) adaptive echo-canceled mono synthetic aperture microphone—to significantly improve audio capture performance in noise-prone or poorly-controlled audio environments, such as office cubicles or public kiosks.
2. One or more data networking protocols, where such protocols may span a range of technological generations. In one embodiment, the present invention includes built-in support for 10 and 100 Megabit-per-second (Mbps) Ethernet, as well as Gigabit Ethernet, via Unshielded Twisted Pair (UTP) wiring. Other embodiments could include support for other or additional networking protocols, such as Asynchronous Transfer Mode (ATM) networking and Integrated Services Digital Network (ISDN).
3. One or more analog A/V signal transmission/reception formats, where such formats may span various means of:
  - a) Analog A/V signal transfer via a separate pair of wires for each of audio transmit, audio receive, video transmit, and video receive (i.e., a total of four sets of UTP wires);
  - b) Analog A/V signal transfer via a single set of UTP wires for audio/video transmit, plus a single set of UTP wires for audio/video receive (i.e., a total of two twisted-pairs carrying analog A/V signals), through frequency modulation (FM) or other multiplexing techniques;
  - c) Analog A/V signal transfer via encoding both audio and video signals on a single set of UTP wires, for example, through FM or other multiplexing methods and perhaps 2-wire/4-wire electronic hybrids; and
  - d) Any of the above approaches that carry the analog A/V signals on the same wire pairs as used by data networking circuits (through the use of FM or other modulation techniques).

Either of the above analog A/V signal transfer formats allow the use of a single conventional data network connector for carrying both analog A/V and data networking signals. For example, a standard 8-wire RJ-45 connector can support 10 and/or 100 MBPS Ethernet in conjunction with analog A/V signal transfer, using two twisted pairs for Ethernet networking and two twisted pairs for A/V signal transfer. In the event that data networking is implemented via a protocol for which a sufficient number of connector pins or wires are unavailable for A/V signal transfer, such as Gigabit Ethernet, which conventionally utilizes the entire physical capacity of an RJ-45 connector, the present invention may include an additional connector or coupling for analog A/V signal transfer.
4. Digital multimedia streaming I/O, transmitted to and/or received from a multimedia network and/or a companion computer, as further described below.
5. Internal A/V signal encoding and decoding capabilities to support A/V compression formats such as MPEG 1/2/4, JPEG, H.310, H.320, H.323, QuickTime, etc.
6. Internal data routing capabilities, through which data packets, cells, or streams may be selectively transferred among a multimedia network, the present invention, and/or a set of companion computers.
7. Multimedia call and connection control protocols, such as described in U.S. Pat. No. 5,617,539.

8. Internet browsing and multimedia internet message transfer capabilities.
9. Data sharing and/or application sharing protocols.
10. Network configuration and/or network traffic monitoring capabilities.

Through the combination of the data routing, internal encoding/decoding, and/or digital streaming capabilities, the present invention may operate as a multimedia processing device that offloads potentially computationally-intensive multimedia processing tasks from a companion computer. Use of the present invention to reduce a companion computer's processing burden can be particularly advantageous in real-time multimedia situations. The present invention may further provide an older or outdated computer with comprehensive real-time multimedia collaboration capabilities, as described below. Additionally, the present invention may operate as a stand-alone device, such as a self-contained internet or intranet appliance having real-time multimedia capabilities, and/or an ISDN video teleconferencing terminal.

The present invention also may advantageously incorporate new technologies, including an integrated camera/display device as described in detail below. Furthermore, the present invention provides support for technology and standards evolution by 1) facilitating the use of standard plug-in and/or replaceable components, which may be upgraded or replaced over time; 2) providing designed-in support for recently-developed technologies that are likely to gain widespread use, such as switched 10 MBPS full-duplex internet, 100 MBPS switched Ethernet, ATM, or Gigabit Ethernet (as well as interim-value networks such as ISDN); and 3) providing for upgradability via software and/or firmware downloads. The present invention may additionally implement particular capabilities via reconfigurable or reprogrammable logic devices, such as Field Programmable Gate Arrays (FPGAs). Updated configuration bitstreams can be downloaded into these reconfigurable devices to provide hardware having upgraded or new capabilities.

#### 4.2 High-Level Architecture and Packaging Options

FIG. 1 is a high-level block diagram of a multimedia collaboration device **100** constructed in accordance with the present invention. The multimedia collaboration device **100** comprises a preamplifier and buffer unit **102**; an audio signal conditioning unit **104**; a switching unit **106**; an Unshielded Twisted Pair (UTP) transceiver **108**; a pair splitter **110**; a routing unit **112**; an encoding/decoding unit **116**; a processor set **118**; a memory **120**; an input device interface **130**; a companion computer port **136**; and a building or premises network port **138**.

The premises network port **138** facilitates coupling to premises- or building-based UTP wiring that forms a portion of a multimedia network **60**. In one embodiment, the premises network port **138** comprises a conventional network coupling, such as an RJ-45 connector. The companion computer port **136** facilitates coupling to one or more host or companion computers **50**, such that the present invention can offload real-time multimedia processing tasks from a companion computer **50** and/or provide a pass-through for data packet exchange between a host computer **50** and the multimedia network **60**. In one embodiment, the companion computer port **136** comprises a conventional network coupling that is compatible with the premises network port **138**. In another embodiment, the premises network port **138** may employ a more sophisticated or modern protocol than that used by the companion computer port **136**. In yet another embodiment, a host or companion computer may access the multimedia collaboration device **100** via the premises network port **138**, and hence such an embodiment may not include a separate com-

panion computer port **136**. It is also possible for the present invention to communicate with a host or companion computer **50** over the data networking ports **136**, **138** for use in running Graphical User Interfaces (GUIs) or coordinating with application processes executing on the host or companion computer **50**.

The preamplifier and buffer unit **102** receives A/V signals from a left and a right microphone **140.1**, **140.2** and a camera **142**, and transmits A/V signals to a left and a right speaker **144.1**, **144.2** and a display device **146**. The preamplifier and buffer unit **102** can additionally send and receive A/V signals via a set of auxiliary (AUX) A/V ports **148**, which could couple to a device such as a Video Cassette Recorder (VCR).

As elaborated upon below, the audio signal conditioning unit **104** provides volume control functionality in conjunction with echo-canceled stereo microphone or mono synthetic aperture microphone capabilities. In one embodiment, the echo-canceled stereo microphone and mono synthetic aperture microphone capabilities may be implemented in a single mode-controlled Digital Signal Processor (DSP) chip, in a manner that may facilitate user-selectivity between these two types of microphone functionality. If the microphone array **140.1**, **140.2** includes more than two microphones, it may be desirable to employ DSP techniques to synthesize a stereo synthetic aperture microphone. Further multiple microphone processing modes, such as stochastic noise suppression for extreme noise environments, can also be included.

In the present invention, transfer of incoming and/or outgoing A/V signals between a variety of sources and/or destinations is required, including the microphones **140.1**, **140.2**, the camera **142**, the speakers **144.1**, **144.2**, the display device **146**, other A/V or I/O devices, the premises network port **138**, and/or the companion computer port **136**. Signal transfer pathways for such sources and destinations may ultimately be analog or digital in nature. To meet these switching needs, the multimedia collaboration device employs the switching unit **106**, which selectively routes analog A/V signals associated with the microphones **140.1**, **140.2**, the camera **142**, the speakers **144.1**, **144.2**, the display device **146**, and/or other devices to or from the analog A/V UTP transceiver **108** and/or the encoding/decoding unit **116**. The encoding/decoding unit **116** may also perform any required conversion between analog and digital formats.

As further described below, the analog A/V UTP transceiver **108** provides an analog signal interface to the pair splitter **110**, which separates data networking and analog A/V signals. In many cases this signal separation is most easily accomplished by selectively separating wires or wire pairs, but may also include the use of passive (or equivalent) wire switching arrangements and programmable Frequency Division Multiplexing (FDM) modulators and demodulators. As indicated earlier, the encoding/decoding unit **116** performs conversions between analog and digital signal formats, and as such also compresses and decompresses A/V signals. Although not shown, those skilled in the art will understand that an ISDN transceiver, inverse multiplexer, network connector, Q.931 call control, etc. . . . can be introduced into the architecture to add support for ISDN. The processor set **118** controls the operation of the multimedia collaboration device **100**, and performs data network communication operations. In conjunction with operating system and other software resident within the memory **120**, the processor set **118** may provide graphic overlay capabilities on a video image so as to implement any GUI capabilities. These GUIs may facilitate control over the operations of the present invention, and may further provide internet browsing capabilities, as described in detail below. The routing unit **112** performs network packet

exchange operations between the premises network port **138**, the companion computer port **136**, and the processing unit **118**, where such packets may include data, portions of, or entire digital AV streams, and/or network configuration or traffic monitoring information. Finally, the input device interface **130** may provide auxiliary mouse and keyboard ports **132**, **134**, and may also support an internal local geometric pointing input device as described below.

Particular groupings of the aforementioned elements may be packaged in various manners so as to match particular deployment settings. For example, selected element groupings may reside within or upon a peripheral box package, computer-bus-compatible card, or housing **150**, where such element groupings may include various A/V transducers. The nature of the selected package **150**, and the manner in which the aforementioned elements are incorporated therein or thereupon as integrated, modular, plug-in, and/or other types of components, is dependent upon the manner in which the present invention is employed, and may be subject to or adaptive to evolving market forces and embedded legacy equipment investments. Three exemplary types of packages are described in detail hereafter.

FIG. **2** is a high-level perspective view illustrating a box package **160** for the multimedia collaboration device **100**. This illustrative box package **160** comprises a housing **162** having a control panel **164** and a cable panel **182**. The control panel **164** includes an audio mode control **166**; a microphone/speaker/headset selector **168**; a microphone mute control **170**; a hold/resume control **172**; AUX video and audio inputs **174**, **176**; a telephone add/remove control **178**; and a speaker/earphone volume control **180**. The audio mode control **166** facilitates user-selection between stereo microphone and synthetic aperture microphone operation, as further described below. The microphone/speaker/headset selector **168** provides for user-selection of different audio input/output interfaces, and the microphone mute control **170** facilitates user control over audio input muting. The hold/resume control **172** pauses or resumes audio inputs in response to user-selection. The AUX video and audio inputs **174**, **176** respectively facilitate video and audio input from various sources. The telephone add/remove control **178** provides control of the insertion of an optional bridge or coupling to a telephone line for two-way audio contact with an addition of third-party telephone user. The supporting electrical couplings would provide for standard telephone loop-through. In one embodiment, the telephone add/remove control **178** includes conventional telephone line echo cancellation circuitry to remove the undesired transmit/receive coupling effects introduced by telephone loops. Finally, the speaker/earphone volume control **180** controls the amplitude of an audio signal delivered to speakers or an earphone (in accordance with the setting of the microphone/speaker/headset selector **168**). Some implementations may include separate volume controls for speakers, earphones, and/or auxiliary audio I/O.

The cable panel **182** on the box package **160** includes inputs and outputs that facilitate coupling to a camera/microphone cable **184**; a premises UTP cable **186**; left and right speaker cables **188**, **190**; a video monitor or video overlay card cable **192**; and a UTP computer networking cable **194**.

The box package **160** is suitable for use with a companion desktop or portable computer, and could reside, for example, underneath, atop, or adjacent to a computer or video monitor. Furthermore, a single box package **160** may be used to provide a plurality of companion computers **50** with multimedia collaboration capabilities, for example, in a small office environment.

Those skilled in the art will understand that the above combination of features is illustrative and can be readily altered. Those skilled in the art will also understand that in an alternate embodiment, the box package **160** could include a built-in microphone or microphone array, as well as one or more speakers. Furthermore, those skilled in the art will understand that one or more controls described above could be implemented via software.

FIG. **3** is a suggestive high-level drawing showing the format of a plug-in card package **200** for the multimedia collaboration device **100**. The plug-in card package **200** comprises a circuit board or card **202** having a standard interface **204** that facilitates insertion into an available slot within a computer. For example, the standard interface **204** could comprise plated connectors that form a male Peripheral Component Interface (PCI) connector, for insertion into a female PCI slot coupled to a PCI bus. The elements comprising the multimedia collaboration device **100** may be disposed upon the card **202** in the form of discrete circuitry, chips, chipsets, and/or multichip modules. The card **202** includes inputs and outputs for coupling to a camera/microphone cable **214**; left and right speaker cables **206**, **208**; a premises UTP cable **210**; and a UTP-to-computer cable **212** that facilitates pass-through of data networking signals to an existing data networking card. It is understood that conventional PCI bus interface electronics and firmware may be added to this configuration. Alternatively, the PCI bus may simply be used to provide power and electrical reference grounding.

The multimedia collaboration device **100** may include more extensive data networking capabilities, capable in fact of supporting essentially all the networking needs of one or more companion or host computers, as described in detail below. In this variation, the plug-in card package **200** may therefore be used to provide a computer into which it is inserted with complete data networking capabilities in addition to multimedia collaboration capabilities via transfer of data networking packets between the interface **204** and the computer, in which case the UTP-to-computer cable **212** may not be necessary. The presence of the plug-in-card package **200** may therefore obviate the need for a separate network interface card (NIC) in market situations in which sufficient evolution stability in data networking technologies exists.

The plug-in card package **200** may be used to provide older or less-capable computers with comprehensive, up-to-date real-time multimedia collaboration capabilities. Alternatively, the plug-in card package **200** can provide video overlay multimedia capabilities to computer systems having a monitor for which a video overlay card is unavailable or difficult to obtain. In the event that video overlay multimedia capabilities are to be delivered to a display or video monitor other than that utilized by the companion computer **50**, the plug-in card package **200** may include a port that facilitates coupling of a video monitor or video overlay card cable **192** in a manner analogous to that shown in FIG. **2**. A host computer **50** that incorporates a plurality of plug-in card packages **200** could be used as a multimedia collaboration server for other computers, in a manner understood by those skilled in the art.

Those skilled in the art will additionally understand that one or more of the physical panel controls described above with reference to the box package **160** would be implemented via software control for the plug-in card package **200**.

FIG. **4** is a perspective view of a stand-alone package **300** for the multimedia collaboration device **100** that includes a range of advantageous internal A/V transducer configurations. In one deployment, the stand-alone package may be attached, mounted, or placed proximate to the side of a com-

puter monitor or laptop/palmtop computer, and hence is referred to herein as a "side-kick" package 300.

The side-kick package 300 provides users with a self-contained highly-localized multimedia communication interface. The incorporation of the microphone array 304 into the side-kick package 300 assists in controlling the present invention's superior audio performance relative to adaptive echo-canceled stereo microphone and adaptive echo-canceled mono synthetic aperture microphone capabilities described below. The placement of the camera 306 in close proximity to the flat display device 312 aids in maintaining good user eye contact with a displayed image, which in turn better simulates natural person-to-person interactions during videoconferencing. The eye contact can be further improved, and manufacturing further simplified, by an integrated camera/display device as described below with reference to FIGS. 16 through 25.

The side-kick package 300 can be used in conjunction with a companion computer 50, or in a stand-alone manner. When used with a companion computer 50, the side-kick package 300 eliminates the need to consume companion computer screen space with a video window. As a stand-alone device, the side-kick package 300 can be used, for example, in office reception areas; public kiosks; outside doorways; or alongside special-purpose equipment for which explicatory, possibly interactive assistance may be useful, such as a photocopier.

Relative to FIG. 2, like reference numbers designate like elements. The side-kick package 300 comprises a housing 302 in which the multimedia collaboration device 100 described above plus additional elements such as an internal shock-mounted microphone array 304; a camera 306 that may include auto-focus, auto-iris, and/or electronic-zoom features; acoustically-isolated stereo speakers 308; a thumb-stick mouse or similar type of geometric input device 310; and a flat display device 312 may reside. The side-kick package 300 may further include display brightness and contrast controls 314, 316, and/or one or more auxiliary audio level controls 180. Additionally, the side-kick package 300 may include a control panel having physical panel controls such as an audio mode control 166; a microphone/speaker/headphone selector 168; a microphone mute control 170; a hold/resume control 172; AUX video and audio inputs 174, 176; and a telephone add/remove control 178, which function in the manner previously described. Those skilled in the art will understand that the functions of one or more of the physical controls shown in FIG. 4 could be implemented so as to be controlled remotely via software. In some arrangements, there might not be any physical controls, in which case control is facilitated by GUIs executing on one or more companion computers 50. Ideally, this embodiment may include both physical and remote software controls so that it can operate as a fully stand-alone device as well as a slave device supporting applications running on the companion computer 50.

The side-kick package 300 has ports for coupling to a premises UTP cable 336 and an optional UTP-to-computer cable 338. The side-kick package 300 may also include another connector set 334, which, for example, facilitates coupling to a headset, an auxiliary mouse, and/or an auxiliary keyboard. FIG. 4 additionally depicts an overlay window 340 upon the flat display device 312, which may be realized via graphics overlay capabilities. The graphics overlay capabilities can implement menus or windows 340 that can provide a user with information such as text or graphics and which may be selectable via the input device 310, creating internal stand-alone GUI capabilities.

Relative to each package 160, 200, 300 described herein, use of the multimedia collaboration device 100 with one or more companion computers 50 to effect digital networked A/V communication advantageously spares each companion computer 50 the immense computational and networking burdens associated with transceiving and encoding/decoding A/V streams associated with A/V capture and presentation. The invention may also incorporate additional video graphics features in any of the packages 160, 200, 300 described above, such as telepointing over live video and/or video frame grab for transference to or from a companion or host computer 50.

While FIG. 1 provides a broad overview of the architecture of the present invention, specific architectural details and various embodiments are elaborated upon hereafter, particularly with reference to FIGS. 5, 6, and 7.

#### 4.3 Architectural Details

FIG. 5 is a block diagram of a first embodiment of a multimedia collaboration device 10 constructed in accordance with the present invention, and which provides primary and auxiliary (AUX) support for analog A/V, and further provides support for networked digital streaming. With reference to FIG. 1, like reference numbers designate like elements. The embodiment shown in FIG. 5 supports analog A/V, and comprises the preamplifier and buffer unit 102; the audio signal conditioning unit 104; the A/V switch 106; the analog A/V UTP transceiver 108; the pair splitter 110; a first and a second digital transceiver 111, 135; the routing unit 112; a network interface unit 114; an analog-to-digital (A/D) and digital-to-analog (D/A) converter 116a; an A/V compression/decompression (codec) unit 116b; at least one, and possibly multiple, processors 118.1, 118.n; the memory 120; the I/O interface 130; and the companion and premises network ports 136, 138. An internal bus 115 couples the network interface unit 114, the A/V codec 116b, each processor 118.1, 118.n, the memory 120, and the I/O interface 130. Each of the audio signal conditioning unit 104, the A/V switch 106, the analog A/V UTP transceiver 108, the routing unit 112, and the A/D-D/A converter 116a may also be coupled to the internal bus 115, such that they may receive control signals from the processors 118.1, 118.n.

The preamplifier and buffer unit 102 is coupled to receive left and right microphone signals from a left and right microphone 140.1, 140.2, respectively; and a camera signal from the camera 142. It is understood that additional microphones 140.3 . . . 140.x and processing 118 and/or switching capabilities 106 may be included to enhance the synthetic aperture microphone capabilities described below. The preamplifier and buffer unit 102 may further receive AUX A/V input signals from one or more auxiliary A/V input devices such as an external VCR, camcorder, or other device. The preamplifier and buffer unit 102 respectively outputs left and right speaker signals to a left and a right speaker 144.1, 144.2; and a display signal to the display device 146. The preamplifier and buffer unit 102 may also deliver AUX A/V output signals to one or more auxiliary devices.

The audio signal conditioning unit 104 facilitates the adjustment of outgoing audio signal volume in conjunction with providing adaptive echo cancelled stereo microphone or mono synthetic aperture microphone processing operations upon audio signals received from the preamplifier and buffer unit 102. FIG. 8 is a block diagram of an adaptive echo-canceled stereo microphone unit 103 within the audio signal conditioning unit 104. The adaptive echo-canceled stereo microphone unit 103 comprises a stereo echo canceller 310 and a stereo volume control unit 350.

The stereo echo canceller **310** comprises conventional monoaural echo canceller subsystems that function in a straightforward manner readily apparent to those skilled in the art. This arrangement includes a left microphone/left speaker (LM/LS) adaptive acoustic echo filter model **312**; a left microphone/right speaker (LM/RS) adaptive acoustic echo filter model **314**; a right microphone/left speaker (RM/LS) adaptive acoustic echo filter model **316**; and a right microphone/right speaker (RM/RS) adaptive acoustic echo filter model **318**. It will be readily understood by those skilled in the art that linear superposition results in stereo echo canceling capabilities for stereo microphones and stereo speakers.

The stereo volume control unit **350** is coupled to a volume adjustment control such as described above with reference to the various package embodiments **160**, **200**, **300** shown in FIGS. **2**, **3**, and **4**, and is further coupled to receive the left and right speaker signals. The stereo volume control unit **350** is also coupled to each model **312**, **314**, **316**, **318** in order to maximize the utilization of DSP arithmetic and dynamic range throughout the full range of speaker volume settings. It is understood that stereo balance controls can be implemented using the same stereo volume control elements operating in complimentary increments.

The LM/LS and LM/RS models **312**, **314** are coupled to receive the left and right speaker signals, respectively. Similarly, the RM/LS and RM/RS models **316**, **318** are respectively coupled to receive the left and right speaker signals **300**. Each of the LM/LS, LM/RS, RM/LS, and RM/RS models **312**, **314**, **316**, **318** incorporates an adaptive coefficient tapped delay line weighting element coupled to its corresponding microphone **140.1**, **140.2** and speaker **144.1**, **144.2** in a conventional manner. Additionally, the LM/LS and LM/RS models **312**, **314** maintain conventional couplings to the left microphone **140.1** to facilitate initial acoustic environment and subsequent adaptive acoustic training operations. Similarly, the RM/LS and RM/RS models **316**, **318** maintain couplings to the right microphone **140.2** to facilitate these types of training operations.

The stereo echo canceller **310** additionally includes a first signal summer **320** coupled to outputs of the left microphone **140.1**, the LM/LS model **312**, and the LM/RS model **314**; plus a second signal summer **322** coupled to outputs of the right microphone **140.2**, the RM/LS model **316**, and the RM/RS model **318**. The first signal summer **320** delivers a left echo-canceled signal to the A/V switch **106**, and the second signal summer **322** delivers a right echo-canceled signal to the A/V switch **106**, in a manner readily understood by those skilled in the art.

In one embodiment, the stereo echo canceller **310** and stereo volume control unit **350** are implemented together via DSP hardware and software. Furthermore, a single DSP may be used to implement the stereo echo canceller **310**, the stereo volume control unit **350**, and the adaptive echo-canceled mono synthetic aperture microphone unit **105**, which is described below. In an exemplary embodiment, such a DSP may comprise a Texas Instruments TMS320C54x generation processor (Texas Instruments Incorporated, Dallas, Tex.).

In the event that a user employs an earphone, headphone set, or AUX audio device in conjunction with the present invention, as described above with reference to the box, card, and side-kick packages **160**, **200**, **300**, the stereo echo canceller **310** is placed in a bypassed, inactive, or quiescent state and the DSP and stereo volume control unit **350** facilitate normalization and/or volume adjustment in a conventional manner as understood by those skilled in the art. Alternatively, separate volume control and/or normalization circuitry

could be provided when stereo microphones or the stereo echo canceller **310** is not needed. These may be implemented in various ways with respect to the paths connecting to the A/V switch.

FIG. **9** is a block diagram of an adaptive echo-canceled mono synthetic aperture microphone unit **105** within the audio signal conditioning unit **104**. With reference to FIG. **8**, like reference numbers designate like elements. The adaptive echo-canceled mono synthetic aperture microphone unit **105** comprises the volume control unit **350** plus a synthetic aperture microphone processing unit **330**, which may include hardware and/or software. The synthetic aperture microphone processing unit **330** comprises a synthetic aperture microphone unit **340** which may include hardware and/or software to implement synthetic aperture microphone processing algorithms; a synthetic microphone/left speaker (SM/LS) model **332**; a synthetic microphone/right speaker (SM/RS) model **334**; and a signal summing circuit **336**, each coupled in the manner shown.

The synthetic aperture microphone unit **330** is coupled to receive the left and right microphone signals, and additionally includes conventional adaptive coefficient weighting and training couplings. Taken together, the synthetic aperture microphone unit **330**, the left microphone **140.1**, and the right microphone **140.2** (plus one or more additional microphones that may be present) form a mono-output synthetic aperture microphone. The synthetic aperture microphone unit **330** performs delay and/or frequency dispersion operations upon the left and right microphone signals to internally create or define an audio reception sensitivity distribution pattern in a manner readily understood by those skilled in the art. The audio reception sensitivity distribution pattern includes one or more spatial regions referred to as "hot-spots," as well as a set of spatial regions referred to as "rejection regions." Typically, a set of one or more "hot-spots" includes a primary hot-spot of maximal audio reception sensitivity that has a particular position or orientation relative to the geometry of the microphone array **140.1**, **140.2**. The rejection regions comprise spatial positions in which the synthetic aperture microphone has minimal audio reception sensitivity.

FIG. **10** is an illustration showing an exemplary localized primary hot-spot **10-3** and a surrounding rejection region **10-8**. Within the primary hot-spot **10-3**, the synthetic aperture microphone **10-2** can detect sound waves produced by a speaker **10-1**. The location of the primary hot-spot may be adjusted in accordance with particular conditions in an acoustic environment. In one embodiment, the position or orientation of the primary hot-spot may be modified under software control. This in turn could facilitate user-directed hot-spot positioning for optimizing audio performance in different acoustic situations. FIG. **11** is an illustration showing exemplary primary hot-spot directivity, where the synthetic aperture microphone **11-2** captures directionally-specific speech energy from a user **11-1** within a primary hot-spot **11-3** that is offset relative to that shown in FIG. **10**. A rejection region **11-8** exists outside the primary hot-spot **11-3** in a conventional manner.

The synthetic aperture microphone can additionally reject reflected speech energy that originated within the primary hot-spot and that approaches the microphone array **140.1**, **140.2** from angles beyond those that span the primary hot-spot. FIG. **12** is an illustration showing exemplary reflected speech energy rejection. The synthetic aperture microphone **12-2** detects sound waves produced by a user **12-1** within a primary hot-spot **12-3**. The synthetic aperture microphone **12-2** rejects sound waves **12-5**, **12-6** originating within the primary hot-spot **12-3** and reflected from nearby surfaces

because the reflected sound waves are likely to travel through one or more rejection regions 12-8 along their reflection path.

The synthetic aperture microphone is further advantageous by virtue of good ambient acoustical noise rejection performance. FIG. 13 is an illustration showing exemplary ambient audio noise rejection, in which a synthetic aperture microphone 13-2 rejects conversational noise 13-4 and various forms of outside or environmental noise 13-5, 13-6, 13-7. The noise and noise reflections traveling towards the microphone array 140.1, 140.2 enter a rejection region 13-8 through various directions, and hence are strongly attenuated via the synthetic aperture microphone's directional rejection behavior. This is in contrast to a user 13-1 within a primary hot-spot 13-3, who produces sound waves that the synthetic aperture microphone 13-2 readily detects with high sensitivity.

Referring also now to FIGS. 5 and 9, the synthetic aperture microphone unit 330 outputs a mono microphone signal having a magnitude that most directly corresponds to the amount of audio energy present within the set of hot-spots, and in particular the primary hot-spot. The synthetic aperture microphone output signal has little contribution from audio energy entering from any rejection region directions. Those of ordinary skill in the art will understand that multiple microphones can be used to extract voice information from background noise that is in fact louder than the actual speech using adaptive cancellation techniques such as those described by Boll and Pulsipher in IEEE Transactions on Acoustics, Speech, and Signal Processing, Vol. ASSP-28, No. 6, December 1980. This could be incorporated as a third operational mode for the audio DSP, for supporting extreme noise environments as might be found on public streets or repair depots, for example.

The volume control unit 350 is coupled to the left and right speaker signals, as are the SM/LS and SM/RS models 332, 334. The signal summing circuit 336 is coupled to the output of the synthetic aperture microphone unit 340, as well as outputs of the SM/LS and SM/RS models 332, 334, and delivers an echo-canceled mono synthetic aperture microphone signal to the A/V switch 106.

In one embodiment, the adaptive echo-canceled synthetic aperture microphone unit 105 comprises DSP hardware and/or software. The present invention can thus provide either adaptive echo-canceled stereo microphone or adaptive echo-canceled mono synthetic aperture microphone capabilities in response to user selection. In an exemplary embodiment, the adaptive echo-canceled synthetic aperture microphone unit 105 is implemented in a DSP such as the Texas Instruments TMS320C54x processor referenced above. Those skilled in the art will recognize that a single DSP system can be configured to provide both the adaptive echo-canceled stereo and mono synthetic aperture microphone capabilities described herein as distinct or integrated operating modes.

In the event that a user employs an earphone, headphone set, or AUX audio devices in conjunction with the present invention, the synthetic aperture microphone unit 330 is placed in a bypassed, inactive, or quiescent state and the DSP and/or volume control unit 350 facilitate conventional normalization and adjustment of output signal amplitude, in a manner understood by those skilled in the art. Alternatively, separate normalization and/or volume control circuitry could be provided to accommodate the aforementioned devices.

Referring again to FIG. 5, the A/V switch 106 comprises conventional analog switching circuitry that is coupled to the preamplifier and buffer unit 102, the audio signal conditioning unit 104, the analog A/V UTP transceiver 108, and the A/D-D/A converters 116a. The A/V switch 106 further maintains a coupling to the internal bus 115, thereby facilitating processor control over A/V switch operation.

The A/V switch 106 routes incoming signals generated by the left and right microphones 140.1, 140.2 (or larger microphone array), the camera 142, and/or any AUX A/V input devices to the analog A/V UTP transceiver 108 or the A/D-D/A converters 116a under the direction of a control signal received via the internal bus 115. Similarly, the A/V switch 106 selects either the analog A/V UTP transceiver 108 or the A/D-D/A converters 116a as a source for outgoing signals directed to the left and right speakers 144.1, 144.2, the display device 146, and/or any AUX A/V output devices.

The analog A/V UTP transceiver 108 comprises a conventional analog A/V transceiver that provides a signal interface to a first set of UTP wires that carry analog A/V signals and which couple the analog A/V UTP transceiver 108 to the pair splitter 110. The pair splitter 110 is further coupled to the first digital transceiver 111 via a second set of UTP wires that carry digital A/V signals. The analog A/V UTP transceiver 108 may be reconfigurable, supporting a range of analog 4-pair, 2-pair, or 1-pair signal transmission methodologies. The selection of any particular signal transmission methodology may be performed under processor control or by physical configuration switching. Similarly, distance compensation adjustments may be performed under processor control or via physical switching, or alternatively through automatic compensation techniques in a manner understood by those skilled in the art.

The first and second digital transceivers 111, 135 provide conventional digital interfaces to UTP wiring, and are coupled to the routing unit 112 in the manner shown. The second digital transceiver 135 is further coupled to the companion computer port 136. The first and second digital transceivers 111, 135 may be implemented using portions of a standard NIC, as described below, or by other means. In addition to the aforementioned couplings, the routing unit 112 is coupled to the network interface unit 114. The routing unit 112 comprises conventional network hub or mini-hub circuitry. In one embodiment, the routing unit 112 performs hard-wired signal distribution and merge functions. In an alternate embodiment, the routing unit 112 performs data packet delivery path selection operations.

The network interface unit 114 comprises conventional network interface circuitry, for exchanging data with the internal bus 115 and data packets with either the multimedia network 60 or a companion computer 50 via the premises and companion computer network ports 138, 136 in accordance with a conventional networking protocol. In one embodiment, the network interface unit 114 is implemented as at least one standard NIC. The NIC may typically include built-in data packet address examination or screening capabilities, and hence simplify the routing unit's function to one of communications distribution and merge functions in such an embodiment. These distribution and merge functions serve to provide simultaneous signal or packet exchange among each of the premises network port 138, the NIC 114, and the companion computer port 136. One advantage of an embodiment employing a standard NIC is that the NIC could be easily replaced or upgraded to accommodate technological evolution. This range of possibilities is further enhanced by the switching arrangement described below with reference to FIG. 15. Although not shown, it is again understood that should ISDN support be deemed valuable, network connectors, interface electronics, inverse multiplexers, and Q.931 call control can be introduced through, for example, connection to the internal bus 115 in a manner familiar to those skilled in the art.

Taken together, the premises network port 138, the pair splitter 110, the analog A/V UTP transceiver 108, the digital

transceiver **111**, the routing unit **112**, the network interface unit **114**, and the companion computer port **136** form 1) a first multimedia network interface for handling analog A/V signals; and 2) a second multimedia network interface for handling digital A/V and data networking signals. FIG. **14** is a block diagram of a first embodiment of a first **400** and a second **410** multimedia network interface provided by the present invention. The first multimedia network interface **400** comprises the aforementioned first set of UTP wires plus the analog A/V UTP transceiver **108**. The first multimedia network interface **400** facilitates the exchange of analog A/V signals between the premises network port **138** and the analog A/V UTP transceiver **108**. The second multimedia network interface **410** comprises the second set of UTP wires, the digital transceiver **111**, the routing unit **112**, and the network interface unit **114**, which are coupled in the manner shown. In some implementations, the digital transceiver **135** may also be a NIC that may be either similar to or different from a NIC employed in the network interface unit **114**. The second multimedia interface **410** facilitates the exchange of digital A/V and data networking signals between the premises network port **138**, the network interface unit **114**, and the companion computer port **136**.

FIG. **15** is a block diagram of a second embodiment of first and second multimedia network interfaces provided by the present invention. The first and second multimedia network interfaces are implemented via a passive switching arrangement and/or an active analog switching matrix **420** that includes low-capacity, high-frequency analog protection devices. Such protection devices may comprise three-terminal, back-to-back diode arrangements, as employed in a Motorola BAV99LT1 (Motorola, Inc., Schaumburg, Ill.). In this arrangement, the analog transceiver **108** may support a number of 4, 2, and 1 pair formats, which may be dictated by the marketplace. Alternatively, the analog transceiver **108** can be a replaceable module.

In the event that data networking is implemented via Gigabit Ethernet or other network protocol that conventionally consumes the entire physical capacity of an entire RJ-45 connector, the present invention may employ an additional RJ-45 or other type of connector for carrying analog A/V signals.

Via the second multimedia network interface, the present invention provides internal data communication transmit, receive, and routing capabilities. An external or companion computer **50** can therefore issue control signals directed to the present invention in accordance with standard data networking protocols. The second multimedia network interface can also provide "loop-through" signal routing between the premises network port **138** and the companion computer port **136**. Additionally, the data routing capabilities provided by the second multimedia network interface facilitate coupling to both existing broadcast or switching hubs. The second multimedia network interface also supports the transfer of digital A/V streams. Thus, the second multimedia network interface cleanly separates data communications directed to one or more companion computers **50**, the multimedia network **60**, and the multimedia collaboration device **10**.

Once again referring to FIG. **5**, each of the A/V switch **106**, the analog A/V UTP transceiver **108**, the routing unit **112**, the network interface unit **114**, the A/V codec **116b**, the set of processors **118.1, 118.n**, the memory **120**, and the I/O interface **130** is coupled to the internal bus **115**. The A/V codec **116b** is further coupled to the A/D-D/A converters **116a**, which are coupled to the A/V switch **106**. It is noted that the A/D-D/A converters **116a** may include color-space conver-

sion capabilities to transform between RGB and YUV or other advantageous color spaces.

The memory **120** comprises Random Access Memory (RAM) and Read-Only Memory (ROM), and stores operating system and application software **122, 124**. Depending upon the nature of the processors **118.1, 118.n**, the operating system **122** could comprise a scaled-down, conventional, or enhanced version of commercially-available operating system software, and/or special-purpose software. In an exemplary embodiment, the operating system **122** comprises Windows CE (Microsoft Corporation, Redmond, Wash.) or another commercial product selected in accordance with the particular environment in which the present invention is employed. The application software **124** may comprise programs for performing videoconferencing, messaging, publishing, broadcast reception, and media-on-demand operations, and internet browsing using programs such as Netscape Navigator (Netscape Communications Corporation, Mountain View, Calif.). Depending upon the nature of the processors **118.1, 118.n**, the internet browser program could be a scaled down, conventional, or augmented version of a commercially-available browser.

The processors **118.1, 118.n** manage communication with the network interface unit **114**, and control the overall operation of the multimedia collaboration device **10** in accordance with control signals received via the network interface unit **114**. The processors **118.1, 118.n** additionally provide graphics overlay capabilities, and may further provide internet browsing capabilities in conjunction with application software **124** as previously described. Relative to managing communication with the network interface unit **114**, the processors **118.1, 118.n** may manage protocol stacks and/or state machines. With regard to controlling the overall operation of the multimedia collaboration device **10**, the processors **118.1, 118.n** issue control signals to the A/V switch **106** and execute application software resident within the memory **120**. The graphics overlay capabilities facilitate the placement of fonts, cursors, and/or graphics over video present upon the display device **146**. With sufficient processing power, the present invention can serve as a stand-alone, real-time video-capable internet appliance.

As described above, the A/D-D/A converters **116a** may comprise conventional circuitry to perform color-space conversion operations in addition to analog-to-digital and digital-to-analog signal conversion. The A/V codec **116b** comprises conventional A/V signal encoding and decoding circuitry, and provides the present invention with compression and decompression capabilities. Together these enable the present invention to encode and decode A/V streams without loading down a companion computer's processing and networking power. Either of the first or second multimedia network interfaces described above can route digital A/V signals to the A/V codec **116b**, while routing non-A/V signals to the companion computer **50**. The present invention's ability to encode and decode A/V signals independent of a companion or external computer is particularly advantageous in situations in which video signal encoding and decoding must occur simultaneously, such as in 2-way teleconferencing or network-based video editing applications. The present invention may support network-based video editing applications based upon a high bandwidth near-zero-latency compression approach, which can be implemented, for example, through JPEG or wavelet compression operations; or an interim compression approach.

In one embodiment, the A/V codec **116b** comprises a chip or chipset. In another embodiment, the A/V codec **116b** comprises a processor **118.k** capable of performing compression

and decompression operations. In more advanced implementations, the A/V codec **116b** could comprise a single processor **118.m** capable of performing user interface functions in addition to A/V compression and decompression operations. Such an implementation could also provide an Application Program Interface (API) in conjunction with operating system software **122**. In an exemplary embodiment of such an implementation, the A/V codec **116b** may comprise a NUON processor (VM Labs, Mountain View, Calif.).

#### 4.4 Additional Embodiments

FIG. 6 is a block diagram of a second embodiment of a multimedia collaboration device **20**, which provides primary support for analog audio I/O and digital visual I/O, and further supports analog and digital auxiliary A/V I/O, plus networked digital streaming. Relative to FIG. 5, like reference numbers designate like elements.

The second embodiment of the multimedia collaboration device **20** includes a digital camera **152**, a digital display device **154**, a digital AUX A/V interface **156**, and a stream selector **158**. The digital camera **152** and the digital display device **154** respectively capture and display images in a conventional manner. The digital AUX A/V interface **156** facilitates bidirectional coupling to auxiliary digital A/V devices, such as an external computer, a digital VCR, or Digital Versatile Disk (DVD) player. Each of the digital camera **152**, the digital display device **154**, and the digital AUX A/V interface **156** is coupled to the stream selector **158**, which is coupled to the A/V codec **116b**.

The stream selector **158** comprises conventional circuitry that selectively routes digital streams between the A/V codec **116b** and the digital camera **152**, the digital display device **154**, and the digital AUX A/V interface **156**. The stream selector **158** may route incoming digital image streams received from either of the digital camera **152** or the digital AUX A/V interface **156** to the A/V codec **116b**. In one embodiment, the stream selector **158** may be capable of multiplexing between these two incoming digital stream sources. Undersampling may also be used to facilitate the compositing of multiple video images. Relative to outgoing digital image streams, the stream selector **158** may route such streams to either or both of the digital display device **154** and digital AUX A/V interface **156**, where such routing may occur in a simultaneous or multiplexed manner. The stream selector **158** additionally facilitates the exchange of digital audio streams between the A/V codec **116b** and the digital AUX A/V interface **156**.

The A/V codec **116b** and the A/D-D/A converters **116a** together facilitate the conversion of digital A/V signals associated with the digital camera **152**, the digital display device **154**, and/or auxiliary digital A/V devices into analog A/V signals. The A/V switch **106** facilitates exchange of these analog A/V signals with AUX A/V devices and/or the premises network port **138**.

Because the A/V codec **116b** is also coupled to the internal bus **115** and hence to the network interface unit **114**, digital A/V signals captured from the digital camera **152** or directed to the digital display **154** or received from the digital AUX A/V interface **156** may be packetized and exchanged via the premises network port **138** and/or the companion computer port **136**.

FIG. 7 is a block diagram of a third embodiment of a multimedia collaboration device **30**, which provides primary support for analog audio I/O and digital visual I/O, support for digital auxiliary A/V I/O, and support for networked digital streaming. Relative to FIGS. 5 and 6, like reference numbers designate like elements.

The third embodiment of the multimedia collaboration device **30** includes a digital camera **152**, a digital display device **154**, a digital AUX A/V interface **156**, and a stream selector **158** in the manner described above. Analog audio signals associated with the microphones **140.1**, **140.2** and speakers **144.1**, **144.2** are routed through the A/D-D/A converters **116a** and A/V codec unit **116b**. Thus, the third embodiment of the present invention manages digital A/V streams, and may exchange such streams with the multimedia network **60** and/or a companion computer **50**. The third embodiment of the multimedia collaboration device **30** does not transmit analog A/V signals over the multimedia network **60**, and hence the analog switching unit **106**, the analog A/V UTP transceiver **108**, and the pair splitter **110** described above relative to the first and second multimedia collaboration device embodiments are not required.

#### 4.5 Camera and Display Device Integration

As previously indicated, placement of the camera **142** in close proximity to the display device **146** aids in maintaining good user eye-contact with a displayed image, thereby closely approximating natural face-to-face communication in videoconferencing situations. Essentially perfect eye-contact can be achieved by integrating a large-area photosensor array with a large-area array of emissive or transmissive devices that form the basis for display device pixels.

Multiple photosensor and display element integration techniques exist. In general, the formation of an image using a photosensor array necessitates the use of optical elements in conjunction with photosensor elements. Photosensor and display element integration techniques are described in detail hereafter, followed by image formation considerations relative to integrated photosensor/display element arrays.

#### 4.6 Display Pixel and Photosensor Element Interleaving

One way of integrating photosensor elements with emissive or transmissive display elements is via element interleaving. FIG. 16 is an illustration showing a first photosensor and display element interleaving technique, in which display elements **510** and photosensor elements **520** populate a viewing screen **502** in an alternating manner. Each display element **510** generates or transmits light corresponding to a particular color or set of colors. Similarly, each photosensor element **520** detects light corresponding to a particular color. As described in detail below, display elements **510** and photosensor elements **520** operate in a temporally and/or spatially separated manner relative to each other to ensure that image capture is essentially unaffected by image display.

Display and photosensor elements **510**, **520** corresponding to a particular color are interleaved in accordance with a color distribution scheme. FIG. 17 is an illustration of an exemplary photosensor element color and display element color distribution scheme. In FIG. 17, display elements **510** corresponding to the colors red, green, and blue are identified via the uppercase letters R, G, and B, respectively. Photosensor elements **520** corresponding to red, green, and blue are respectively identified by the lowercase letters r, g, and b. Display elements **510** corresponding to a particular color are offset relative to each other, and interleaved with display and photosensor elements **510**, **520** corresponding to other colors. Similarly, photosensor elements **520** corresponding to a particular color are offset relative to each other, and interleaved with display and photosensor elements **510**, **520** corresponding to other colors. Those skilled in the art will recognize that a variety of photosensor and display element color distribution schemes are possible.

The presence of photosensor elements **520** interleaved with display elements **510** reduces image resolution, and increases pixel pitch (i.e., the spacing between pixels). To

minimize the effect that the photosensor elements **520** have upon the appearance of a displayed image, photosensor elements **520** having or consuming a smaller area than the display elements **510** are employed. Furthermore, various display and photosensor element layout geometries may be used to produce an interleaving pattern that closely approximates display element pitch found in conventional display devices. FIG. **18** is an illustration of a second photosensor and display element interleaving technique, in which photosensor and display element geometries and size differentials aid in minimizing pixel pitch and maximizing displayed image resolution. Since a viewer's eye will integrate or average the light output by groups of display elements **510**, interleaving techniques of the type shown in FIG. **18** ensure that the viewer will perceive a high-quality image. Those skilled in the art will understand that various microoptic structures or elements, such as microlenses, could be employed in the nonluminant spaces between display elements **510** and/or photosensor elements **520** to reduce or minimize a viewer's perception of nonluminant areas in a displayed image. Such microoptic structures are elaborated upon below.

The display elements **510** referred to herein may comprise essentially any type of conventional light emitting or transmitting device, such as a Light Emitting Diode (LED) or Liquid Crystal Display (LCD) pixel element. Similarly, the photosensor elements **520** may comprise essentially any type of conventional light sensing or detecting device. For example, the photosensor elements **520** could comprise photodiodes, such as Schottky or p-i-n photodiodes; phototransistors; capacitive or charge-coupled devices (CCDs); charge modulated devices (CMDs); or other types of light-sensitive devices. The photosensor elements **520** could be fabricated, for example, using standard semiconductor processing techniques employed during the manufacture of flat panel displays.

In a typical display device, a single display element **510** is used to output light of a particular color. Display elements **510** based upon organic electroluminescence are capable of simultaneously generating light comprising multiple wavelengths in the visible spectrum, and form the basis for full-color LED arrays. In particular, a single Stacked Organic Light Emitting Diode (SOLED) pixel element can produce red, green, and blue light. The intensity of each color is independently tunable, as is each color's mean wavelength. Thus, a single SOLED can form a full-color pixel. As an alternative to organic electroluminescent materials, the present invention may employ other full-color transparent or semitransparent luminescent materials, such as light-emitting and/or light-responsive polymer films.

FIG. **19** is a cross-sectional view showing a full-color pixel array integrated with a photosensor element array upon a common substrate **702** such as glass or plastic. As an example, a SOLED **710** is considered as the full-color pixel technology in the discussion that follows. Those skilled in the art will understand that the concepts described herein can be applied to other full-color pixel technologies. Each SOLED **710** comprises a first, second, and third semitransparent electrode **712**, **714**, **716**; a first, second, and third organic electroluminescent layer **722**, **724**, **726**; and a reflecting contact layer **730**, in a manner understood by those skilled in the art. Each electroluminescent layer **722**, **724**, **726** emits light in a particular wavelength range in response to an applied electric field. For example, the first, second, and third organic electroluminescent layers **722**, **724**, **726** could respectively output blue, green, and red light.

A color filter **750**, an optional microoptic structure **760**, and a photosensor element **520** form a color-specific photo-

sensor element **770** that is fabricated adjacent to each SOLED **710**. The microoptic **760** may comprise one or more microlenses, apertures, and/or other types of planar optic structures, and serves to focus incoming light onto the photosensor element **520** to aid image formation in the manner described below. The microoptic structure **760** may be formed through the application of conventional microlens or planar optic fabrication techniques during photosensor element fabrication steps. For example, the microoptic structure **760** may be formed by depositing a selectively-doped dielectric or dielectric stack prior to or during photosensor element fabrication, in a manner well understood by those skilled in the art.

The color-specific photosensor element **770** may also include one or more antireflection layers, which are deposited in a conventional manner. Additionally, one or more types of passivation or isolation materials, such as Silicon Dioxide, Silicon Nitride, Polyimide, or spin-on-glass may be deposited in between each SOLED **710** and color-specific photosensor element **770** in a manner understood by those skilled in the art.

Each color-specific photosensor element **770** detects light characterized by a specific wavelength interval. Thus, while any given SOLED **710** may simultaneously output red, green, and/or blue light, separate color-specific photosensor elements **770** are used to individually detect red, green, and blue light. Because each SOLED **710** forms a full-color pixel, integration of a SOLED array with a photosensor array in the manner shown in FIG. **19** is particularly advantageous relative to providing a high-resolution display having image capture capabilities.

#### 4.7 Display and Photosensor Element Stacking

##### a) Integrated SOLED/Photosensor Element

A full-color pixel element such as a SOLED **710** and a color-specific photosensor element **770** can be integrated together, such that the incorporation of a photosensor element array into a display element array can be accomplished essentially without a resolution or pixel pitch penalty. FIG. **20** is a cross-sectional view showing an integrated full-color pixel/photosensor element **800**, which may form the basis of an integrated display element/photosensor element array. For purpose of example, the full-color pixel element is considered to be a SOLED **810** in the description that follows. Those skilled in the art will understand that other types of full-color pixel technologies could be used to produce the integrated full-color pixel/photosensor element **800** described hereafter.

Relative to FIG. **19**, like reference numbers designate like elements. The full-color pixel/photosensor element **800** comprises a SOLED **810** having a color-specific photosensor element **770** fabricated thereupon. The full-color pixel/photosensor element **800** is fabricated upon a substrate **702** such as glass. The SOLED **810** comprises a first, a second, a third, and a fourth semitransparent electrode **712**, **714**, **716**, **812**; a first, second, and third organic electroluminescent layer **722**, **724**, **726**; and a patterned reflecting contact layer **830**.

With the exception of the fourth semitransparent electrode **812** and the patterned reflecting contact layer **830**, the SOLED **810** shown in FIG. **20** is essentially the same as that depicted in FIG. **19**. The fourth semitransparent electrode **812** serves as one of the electrodes for the photosensor element **520** within the color-specific photosensor element **770**, in a manner readily understood by those skilled in the art. Deposition of the fourth semitransparent electrode **812** may not be required under the patterned reflecting contact layer **830**, and as such the SOLED **810** and color-specific photosensor element **770** may not share a common electrical interface layer.

The patterned reflecting contact layer **830** comprises conventional contact materials or metals that have been patterned to include a gap or opening.

The color-specific photosensor element **770** is fabricated on top of the fourth semitransparent electrode **812**, in the opening defined in the patterned reflecting contact layer **830**. The color-specific photosensor element **770** thus detects light that has been transmitted through the substrate **702** and each of the first through fourth semitransparent electrodes **712**, **714**, **716**, **812**. Those skilled in the art will understand that the location of the opening defined in the patterned reflecting contact layer **830**, and hence the location of the color-specific photosensor element **770** upon the SOLED **810**, may vary among adjacent full-color pixel/photosensor elements to ensure that the human observer perceives a high-quality displayed image. The SOLED **810** and the color-specific photosensor element **770** may operate in a temporally-separated manner to ensure that image capture is essentially unaffected by image display, as further elaborated upon below.

#### b) Stacked Full-Color Emitter/Full-Color Detector Structures

A full-color pixel element, such as a stacked organic electroluminescent (SOE) structure, may also be used to detect light. Thus, a single structure based upon full-color materials technology may be used for both RGB light emission and RGB light detection, thereby advantageously facilitating the integration of a photosensor element array and a display element array while maintaining small pixel pitch and high image resolution.

FIG. **21** is a cross-sectional view of a first full-color emitter/detector **900**. In the description that follows, the first full-color emitter/detector **900** is considered to be an SOE-based device. Those skilled in the art will recognize that other full-color technologies could be employed to produce the first full-color emitter/detector **900** in alternate embodiments.

Relative to FIGS. **19** and **20**, like reference numbers designate like elements. The first full-color emitter/detector **900** is fabricated upon a substrate **702** such as glass, and comprises first through seventh semitransparent electrodes **712**, **714**, **716**, **812**, **912**, **914**, **916**; first through sixth organic electroluminescent layers **722**, **724**, **726**, **922**, **924**, **926**; an optional microoptic structure **920**; and a reflecting contact layer **730**.

In the first full-color emitter/detector **900**, the first through third organic electroluminescent layers **722**, **724**, **726** serve as RGB light emitters controlled by voltages applied to the first through fourth semitransparent electrodes **712**, **714**, **716**, **812**, and thus form a SOLED **902**. The microoptic structure **920** comprises one or more microlenses, apertures, and/or other planar microoptic structures that focus incoming light into the fourth, fifth, and sixth organic electroluminescent layers **922**, **924**, **926**, which in turn produces or induces pairwise voltage differences across the fifth, sixth, and seventh semitransparent electrodes **912**, **914**, **916** and the reflecting contact layer **730**. The microoptic structure **920**, the fourth through sixth organic electro-luminescent layers **922**, **924**, **926**, the fifth through seventh semitransparent electrodes **912**, **914**, **916**, and the reflecting contact layer **730** therefore form a first SOE photosensor **904** for detecting RGB light.

Light emitted by the SOLED **902** may travel through the substrate **702** toward a viewer, or through the first SOE photosensor **904**, where it is reflected back toward the substrate **702** by the reflecting contact layer **730**. The first SOE photosensor **904** detects incoming light that has traveled through the substrate **702** and the SOLED **902**. As described in detail below, SOLED light emission and SOE photosensor light

detection may occur in a temporally and/or spatially separated manner, such that image capture is essentially unaffected by image display.

Those skilled in the art will recognize that the SOLED **902** and the first SOE photosensor **904** may be able to share a single semitransparent electrode at their interface in an alternate embodiment (i.e., the first full-color emitter/detector **900** may be fabricated without one of the fourth or fifth semitransparent electrodes **812**, **912**) since SOLED and SOE photosensor operation within a single first full-color emitter/detector **900** may be temporally separated). Those skilled in the art will also understand that in addition to the layers described above, the first full-color emitter/detector **900** may include additional microoptic layers and/or one or more antireflective layers. Those skilled in the art will further recognize that in an alternate embodiment, the first full-color emitter/detector **900** could be fabricated such that the first SOE photosensor **904** resides in contact with the substrate **702**, and the SOLED **902** resides on top of the first SOE photosensor **904**. In such an embodiment, the reflecting contact layer **730** would be incorporated into the SOLED **902**. Those skilled in the art will also recognize that either or both of the SOLED **902** and the first SOE photosensor **904** could be implemented using other types of transparent or semitransparent full-color device and/or materials technologies in alternate embodiments.

FIG. **22** is a cross-sectional view of a second full-color emitter/detector **1000**. For ease of understanding, the second full-color emitter/detector is considered to be based upon SOE technology in the following description. Those skilled in the art will recognize that other full-color materials technologies could be employed to produce the second full-color emitter/detector **1000** in alternate embodiments.

Relative to FIG. **20**, like reference numbers designate like elements. The second full-color emitter/detector **1000** is fabricated upon a substrate **702** such as glass, and comprises a first through fifth semitransparent electrode **712**, **714**, **716**, **812**, **1012**; a first through sixth organic electroluminescent layer **722**, **724**, **726**, **1022**, **1024**, **1026**; an optional microoptic structure **1020**; a first, a second, and a third reflecting contact layer **1032**, **1034**, **1036**; and a first and a second boundary structure **1042**, **1044**.

The first through third organic electroluminescent layers **722**, **724**, **726**, in conjunction with the first through fourth semitransparent electrodes **712**, **714**, **716**, **812**, form a SOLED **902** in a manner analogous to that described above with reference to FIG. **21**. The microoptic structure **1020**, the first through third organic electroluminescent layers **1022**, **1024**, **1026**, the reflecting contact layers **1032**, **1034**, **1036**, and the first and second boundary structures **1042**, **1044** form a second SOE photosensor **1004**.

Taken together, the fourth, fifth, and sixth organic electroluminescent layers **1022**, **1024**, **1026** and the boundary structures **1042**, **1044** span an area essentially equal to that of any semitransparent electrode **712**, **714**, **716**, **812**, **1012**. The first boundary structure **1042** separates the fourth and fifth organic electroluminescent layers **1022**, **1024**. Similarly, the second boundary structure **1044** separates the fifth and sixth organic electroluminescent layers **1024**, **1026**. The first, second, and third reflecting contact layers **1032**, **1034**, **1036** respectively reside upon or atop the fourth, fifth, and sixth organic electroluminescent layers **1022**, **1024**, **1026**.

The microoptic structure **1020** may comprise one or more microlenses, apertures, and/or other planar microoptic structures that focus incoming light into the fourth, fifth, and sixth organic electroluminescent layers **1022**, **1024**, **1026**. The fourth organic electroluminescent layer **1022** detects incoming photons having a wavelength range associated with a

particular color, for example, red. The presence of such photons in the fourth organic electroluminescent layer produces or induces a voltage difference between the fourth semitransparent electrode **1012** and the first reflecting contact layer **1032**. Similarly, the fifth and sixth organic electroluminescent layers **1024**, **1026** each detect incoming light corresponding to a particular wavelength range, for example, green and blue, respectively. The presence of blue and green light respectively induces a voltage difference between the second and third reflecting contact layers **1034**, **1036** and the fourth semitransparent electrode **1012**.

Those skilled in the art will recognize that the thickness of each of the fourth, fifth, and sixth organic electroluminescent layers **1022**, **1024**, **1026** may be varied in accordance with the particular wavelength range that each such layer is to detect. Those skilled in the art will additionally recognize that the microoptic structure **1020** may be fabricated such that its characteristics vary laterally from one organic electroluminescent layer **1022**, **1024**, **1026** to another, and that one or more antireflection layers may be incorporated into the second full-color emitter/detector **1000**. Moreover, the SOLED **902** and the second SOE photosensor **1004** may be able to share a single semitransparent electrode at their interface a manner analogous to that described above relative to the first SOE photosensor **904**. Finally, those skilled in the art will recognize that either or both of the SOLED **902** and the second SOE photosensor **1004** could be implemented using other types of transparent or semitransparent full-color technologies in alternate embodiments.

#### 4.8 Other Integrated Emitter/Detector Structures

As indicated above, a light detecting element may be similar, nearly, or essentially identical in structure and/or composition to a light emitting element. Because any given emitter/detector structure may be used for light emission during one time interval and light detection during another time interval as described below, a single light emitting structure may also be used for light detection.

FIG. **23** is a cross-sectional diagram of a third full-color emitter/detector **1100**. For ease of understanding, the third full-color emitter/detector is described hereafter in the context of SOE technology. Those skilled in the art will understand that other full-color materials and/or technologies could be employed to produce the third full-color emitter/detector **1100** in alternate embodiments.

Relative to FIG. **19**, like reference numbers designate like elements. The third full-color emitter/detector **1100** is fabricated upon a substrate **702** such as glass or plastic. The third full-color emitter/detector **1100** comprises a SOLED **710** having a first through a third semitransparent electrode **712**, **714**, **716**; a first, a second, and a third organic electroluminescent layer **722**, **724**, **726**; a reflecting top contact layer **730**. The third full-color emitter/detector **1000** may additionally include a microoptic layer **1120**. During a first time interval, the SOLED **710** may operate in a light emitting mode in a conventional manner. During a second time interval, the SOLED **710**, in conjunction with the microoptic layer **1120**, operates as a photosensor to detect incoming light in a manner analogous to that described above relative to the SOE photosensors **904**.

The microoptic layer **1120** may comprise a microlens and/or other type of planar optic structure, and may be fabricated such that different portions of the microoptic layer **1120** affect light in different manners. This in turn could aid in providing particular light detection responsivity while minimally affecting the manner in which light emitted by the third full-color emitter detector **1100** will be perceived by a human eye.

FIG. **24** is a top-view of an exemplary microoptic layer **1120** having different optical regions **1190**, **1192** defined therein. A first optical region **1190** may allow light to pass in an essentially unaffected manner. A second optical region **1192** serves as a focusing element that produces a desired spatial or modal light intensity pattern within the third full-color emitter/detector. As the second optical region **1192** occupies a smaller area than the first optical region **1190**, its affect upon human perception of light emitted by the third full-color emitter/detector may be small or minimal. Those skilled in the art will understand that the location of the second optical region **1192** may vary among adjacent third full-color emitter/detectors **1100**, to further enhance the quality of a displayed image seen by a human eye.

In an alternate embodiment, the microoptic layer **1120** could include additional optical regions. For example, one or more portions of the first optical region **1190** could be designed or fabricated to compensate for any effects the second optical region **1192** has upon human perception of light emitted by the third full-color emitter/detector **1100**. As another example, the second optical region **1192** could be replaced or augmented with other, possibly smaller, optical regions distributed across the plane of the microoptic layer **1120** to further optimize light detection and emission characteristics.

#### 4.9 Image Formation

A simple or compound lens is conventionally used to focus an image onto an array of photosensors. FIG. **25** illustrates a simple or compound lens **600** that receives or collects light **602** reflected or emanating from an object **604**, and focuses such light onto a photosensor element array **606**.

Relative to a single array that integrates both display and photosensor elements **510**, **520**, the use of a conventional simple or compound lens would adversely affect the characteristics of the displayed image. To facilitate image detection in such an integrated array, photosensor elements **520** may incorporate microoptic structures and/or apertures, as described above, on an individual basis. Each aperture and/or microoptic structure focuses light received from a small portion of an object onto a photosensor element **520**. As depicted in FIG. **25**, sets of microoptic-equipped photosensor elements **520** within a photosensor array **620** receive light **622**, **624** emanating from different parts of an object **626**. Those skilled in the art will recognize that the present invention could employ microoptic structures or elements that focus light onto multiple photosensor elements **520** in alternate embodiments, where such microoptic elements may be incorporated onto separate substrates. Signals output by the microoptic-equipped photosensor elements **520** are transferred to an image processing unit **628** for further processing, as described in detail below.

Conventional display devices comprise multiple rows or lines of display elements **510**, and produce a displayed image on a line-by-line basis. Similarly, conventional photosensor arrays comprise multiple rows of photosensor elements **520**, which may be scanned on a line-by-line basis during image capture operations. The integrated display element/photosensor element arrays considered herein may also 1) produce a displayed image by activating display elements **510** on a line-by-line basis; and 2) capture light received from an object by detecting photosensor element output signals on a line-by-line basis.

In one embodiment, the present invention includes a display control circuit for performing display line scans that produce a displayed image on a line-by-line basis, and a capture control circuit for performing photosensor line scans that read photosensor element output signals on a line-by-line

basis. Each of the display and capture control circuits include conventional clocking, address decoding, multiplexing, and register circuitry. In order to ensure that image capture is essentially unaffected by image display (i.e., to prevent light emitted or transmitted by display elements 510 from affecting incoming light detection by adjacent photosensor elements 520), the display line scans and photosensor line scans may be temporally and/or physically separated relative to each other. This separation may be controlled via conventional clocking and/or multiplexing circuitry.

In one embodiment, photosensor line scans are initiated after a display line scan has generated fifty percent of an image (i.e., after fifty percent of the display element lines have been activated during a single full-screen scan cycle), such that the photosensor line scan trails the display line scan by a number of display element rows equal to one-half of the total number of display element rows present in the integrated display element/photosensor element array. More generally, the capture line scan could trail the display line scan by a particular time interval or a given number of completed display line scans.

In another embodiment, one-half of the display element lines define a first display field, and one-half of the display element lines define a second display field, in a manner well understood by those skilled in the art. Similarly, one-half of the photosensor element lines define a first photosensor field, and the remaining photosensor element lines define a second photosensor field. The first display field and either of the first or second photosensor fields may be scanned either simultaneously or in a time-separated manner, after which the second display field and the remaining photosensor field may be scanned in an analogous manner. Those skilled in the art will recognize that the display and photosensor field scanning can be performed in a manner that supports odd and even field scanning as defined for NTSC and PAL television standards.

In yet another embodiment, a single full-screen display line scan cycle is completed, after which a single full-screen photosensor line scan cycle is completed, after which subsequent full-screen display line and photosensor line scans are separately performed in a sequential manner.

The set of photosensor element output signals received during any given photosensor line scan are transferred to an image processing unit 628. The image processing unit 628 comprises signal processing circuitry, such as a DSP, that performs conventional digital image processing operations such as two-dimensional overlap deconvolution, decimation, interpolation, and/or other operations upon the signals generated during each photosensor line scan. Those skilled in the art will understand that the number and types of digital image processing operations performed upon the signals generated during each photosensor line scan may be dependent upon the properties of any microoptic structures associated with each photosensor element 520. Those skilled in the art will further understand that signal conditioning circuitry may additionally be present to amplify photosensor element signals or eliminate noise associated therewith. Such signal conditioning circuitry, or a portion thereof, may be integrated with each photosensor element 520.

The image processing unit 628 forms a conventional final output image array using signal processing methods, and outputs image array signals to a buffer or memory, after which such signals may be compressed and incorporated into data packets and/or converted into analog video signals for subsequent transmission, where the compression and/or conversion may occur in conjunction with associated audio signals.

The signal processing algorithms employed in image formation are determined by the nature of any microoptic ele-

ments employed in conjunction with the photosensor elements 520. Such algorithms may perform deconvolution, edge-effect handling, decimation, and/or interpolation operations in a manner understood by those skilled in the art.

For example, if the microoptic elements amount to tiny apertures that limit detector pixel source light to non-overlapping segments in the principal area of view, the signal processing amounts to aggregating the pixels into an array and potentially performing interpolation and/or decimation operations to match the resolution of the pixel detector array to that of the final desired image.

As detection pixels overlap by increasing amounts, the applied signal processing operations can advantageously sharpen the image by deconvolving the impulse response of the pixel overlap function. Depending upon the microoptic arrangement employed, which may be dictated by device cost and fabrication yield or reliability, the overlap impulse response takes on varying characteristics, affecting the algorithm the image processing unit 628 is required to perform. In general, the deconvolution can be handled as either a set of two-dimensional iterated difference equations, which are readily addressed by standard numerical methods associated with the approximate solution of differential equations, or through conversions to the frequency domain and appropriate division operations. Further, if the overlap function is highly localized, which can be a typical situation, the difference equations can be accurately approximated by neglecting higher-order terms, which greatly simplifies the resulting operations. This is in contrast to frequency domain techniques for this case, as localization in the impulse response implies immense nonlocalization in the transform domain. However, should the overlap impulse response itself be far less localized, frequency domain deconvolution methods may be advantageous. Care must be taken in limiting the division to relevant areas when there are zeros in the frequency-domain representation of the overlap impulse response (transfer function).

Edge effects at the boundaries of the pixel detector array can be handled by various methods, but if the overlap impulse response is kept localized by apertures and/or other microoptic elements, then undesirable edge effects in the final image formation (that may result from "brute-force" treatment of the edges) quickly vanish within a few pixels from the boundary of the final formed image. Cropping can then be employed to avoid such edge effect altogether. Thus, by creating a slightly-oversized pre-final image formation array and eliminating edge effect by cropping, a final image array of desired resolution having no edge effects induced by overlap impulse responses can be readily produced.

It is known to those skilled in the art that in general, aperture effects invoked by actual apertures and/or microoptic elements can create diffraction patterns or spatial intensity modes in the light transmitted through the optical structure. Such optical structures may be designed to enhance or eliminate particular modes or diffraction effects, in a manner readily understood by those skilled in the art.

While the teachings presented above have been described in relation to a display device having a camera or image capture capabilities integrated therein or thereupon, the above teachings relating to 1) various photosensor element, microoptic and/or apertured structures; and 2) image processing requirements for creating an array of image signals that correspond to a captured image can be applied to effectively create a camera disposed or integrated upon any one of a wide variety of surfaces or substrates, including glass, plastic, partially-silvered mirrors, or other materials. Photosensor elements 520 disposed upon such substrates may be organized or

distributed in a manner similar to that shown above with reference to FIGS. 16, 17, and 18, with the exception that display elements 510 shown in those figures may not be present.

The principles of the present invention have been discussed herein with reference to certain embodiments thereof. Study of the principles disclosed herein will render obvious to those having ordinary skill in the art certain modifications thereto. The principles of the present invention specifically contemplate all such modifications.

The invention claimed is:

1. A display device having image capture capabilities for at least one distant image source, the display device comprising:
  - a plurality of display elements;
  - a plurality of photosensor elements, the plurality of photosensor elements interleaved with the plurality of display elements in an essentially planar arrangement, such that the essentially planer arrangement can function as a display for the display device and to perform image capture simultaneously;
 wherein the plurality of photosensor elements is configured to receive light from a distant non-adjacent image source separated from the display device by empty space, and
  - wherein the photosensor elements create output signals responsive to the received light from a distant non-adjacent image source for presentation to signal processing arranged for image formation to form a synthetic image, the synthetic image responsive to the light received from the distant non-adjacent image source.
2. The display device of claim 1, wherein at least one microoptic structure is associated with a set of photosensor elements.
3. The display device of claim 2, wherein a dedicated microoptic structure is associated with each photosensor element within the set of photosensor elements.
4. A system for image formation comprising:
  - a set of photosensor elements, each configured to generate a photosensor output signal in response to light received thereon from a distant non-adjacent object;
  - a plurality of display element interleaved with the photosensor element in an essentially planar arrangement such that the essentially planer arrangement can function as a display and to perform image capture simultaneously, the display elements being configured to emit light representative of a respective display signal;
  - a plurality of micro-optic elements, each of which is configured to direct light from a portion of the distant non-adjacent object separated from the micro-optic elements by empty space onto a respective subset of the set of photosensor elements; and
 at least one signal processor configured to:
  - receive photosensor output signals from the set of photosensor elements,
  - perform an image formation operation on the received photosensor output signals to create first image data,
  - perform a digital processing operation on the first image data to produce second image data, the digital processing operation including at least one of an edge effect handling operation to remove edge effects, a sharpening operation and an aggregation operation, and
  - provide output image data based on the second image data, the output image data representing a portion of an image of the distant non-adjacent object.

5. The system of claim 4, wherein the photosensor elements are arranged in a first array and the micro-optic elements are arranged in a second array.

6. The system of claim 5, wherein the image formation operation includes a deconvolution operation based on an overlap impulse response determined by properties of respective micro-optic elements associated with each of the set of photosensor elements.

7. The system of claim 6 wherein the deconvolution operation comprises a two-dimensional overlap deconvolution operation.

8. The system of claim 4, wherein the sharpening operation comprises removing effects in the first image data due to overlap of the photosensor elements.

9. The system of claim 4, wherein the micro-optic elements are fabricated as a component of respective photosensor elements.

10. The system of claim 4, wherein the micro-optic elements are fabricated using at least one of a micro lens fabrication technique and a planar optic fabrication technique.

11. The system of claim 4, wherein the at least one signal processor is further configured to perform at least one of a decimation operation and an interpolation operation on at least one of the photosensor output signals and the first image data.

12. The system of claim 4, wherein the edge effects are caused by a first set of photosensor elements positioned within a peripheral region of the photosensor array.

13. The system of claim 4, wherein the edge effect handling operation to remove edge effects comprises a crop operation to remove from subsequent processing portions of the first image data.

14. The system of claim 4, wherein the micro-optic elements are configured in a configuration to reduce edge effects in the output image data.

15. The system of claim 4, wherein the micro-optic elements are configured to have a localized overlap impulse response.

16. The system of claim 4, wherein the aggregation operation comprises the aggregation of processed versions of the first image data.

17. A system for image formation comprising:

a plurality of photosensor elements arranged in a first array;

a plurality of display elements interleaved with the photosensor elements in an essentially planer arrangement such that the essentially planar arrangement can function as a display and to perform image capture simultaneously, the display elements being configured to emit light representative of a respective display signal;

a plurality of micro-optic elements, each of the micro-optic elements configured to direct received light from a portion of a distant non-adjacent object separated from the plurality of micro-optic elements by empty space, onto a respective subset of the photosensor elements, each of the photosensor elements configured to generate a photosensor output signal in response to received light;

a capture control circuit configured to scan the output signals generated by the photosensor elements on a line-by-line basis; and

an image processing unit configured to:

receive from the capture control circuit the photosensor output signals generated during a respective photosensor line scan;

perform at least one digital image processing operation on the photosensor output signals generated during the photosensor line scan; and

31

based on the signals generated by the digital image processing operation, provide respective output image signals, each of which represents a respective portion of an image of the distant non-adjacent object, wherein each of the respective image signals are responsive to receive light from the distant nonadjacent image source. 5

18. The system of claim 17, further comprising: signal conditioning circuitry configured to perform at least one signal conditioning operation including at least one of amplifying the photosensor output signals and reducing noise in the output signals generated by the photosensor elements. 10

19. The system of claim 18, wherein the signal conditioning circuitry is integrated with the plurality of photosensor elements.

20. A method for image formation comprising: using a plurality of micro-optic elements to direct light received from a portion of a distant non-adjacent object separated from the plurality of micro-optic elements by empty space onto a respective plurality of photosensor elements; 15

emitting light represented by a display signal by using display elements interleaved with the photosensor elements in an essentially planar arrangement such that the essentially planar arrangement can function as a display for the display device and to perform image capture simultaneously; 20

32

generating from each of the photosensor elements a photosensor output signal in response to light received thereon;

receiving the photosensor output signals and performing thereon at least one image formation operation and a digital processing operation, wherein the digital processing operation includes one of an edge effect handling operation to remove edge effects represented in the output signals, a sharpening operation and an aggregation operation; and

outputting from the digital processing operation respective image signals, each of which represents a respective portion of an image of the distant non-adjacent object,

wherein each of the respective image signals is responsive to receive light from the distant nonadjacent image source.

21. The method of claim 20, further comprising:

arranging the plurality of photosensor elements in a first array; scanning the photosensor output signals generated by the photosensor elements on a line-by-line basis; and performing the digital image processing operation on photosensor output signals generated during the line-by-line photosensor scan.

\* \* \* \* \*

|                |  |         |            |
|----------------|--|---------|------------|
| 专利名称(译)        | 结合显示和图像捕获，无需简单或复合镜头，用于视频会议眼睛接触和其他应用                        |         |            |
| 公开(公告)号        | <a href="#">US8754842</a>                                  | 公开(公告)日 | 2014-06-17 |
| 申请号            | US12/419229  | 申请日     | 2009-04-06 |
| [标]申请(专利权)人(译) | AVISTAR COMM   |         |            |
| 申请(专利权)人(译)    | AVISTAR通信集团公司  |         |            |
| 当前申请(专利权)人(译)  | 路德维希LESTER F.  |         |            |
| [标]发明人         | LUDWIG LESTER F  |         |            |
| 发明人            | LUDWIG, LESTER F.  |         |            |
| IPC分类号         | G09G3/36 H04N7/14  |         |            |
| CPC分类号         | H04N7/14 G06T5/003 H04N3/12 H04N5/238                      |         |            |
| 审查员(译)         | BODDIE, WILLIAM  |         |            |
| 优先权            | PCT/US1999/001789 1999-01-27 WO<br>60/072762 1998-01-27 US |         |            |
| 其他公开文献         | US20090231474A1  |         |            |
| 外部链接           | <a href="#">Espacenet</a> <a href="#">USPTO</a>            |         |            |

摘要(译)

没有简单或复合透镜的集成显示器和照相机，包括交错的发光和光敏/光电传感器元件。不使用简单或复合透镜的图像形成可以通过在光感测量上操作的软件算法获得，例如实现由微光学阵列施加的传递函数定义的二维反卷积操作。例如，微光学孔径阵列可以被配置为包括局部光学重叠，其可以通过算法容易地解卷积或以其他方式求解。相关的微光学结构可以像孔一样简单或者可以更复杂，例如包括微透镜。显示器和光电传感器元件可包括颜色能力。光敏元件在结构和/或组成上与发光元件相似，几乎或基本相同。发光元件可以包括有机发光二极管，并且可以配置用于光检测模式，例如发光和同时检测光。应用包括在视频会议中提供目光接触。

